



OWNER'S MANUAL

DIGIFLY AIR-PRO Series

Ver. 704a – English - Rev.2

CONGRATULATIONS

Thank you for choosing Digifly!

You have purchased a high technology instrument designed expressly for free-flight. The multiple functions and flight data it provides effectively make it an on-board computer. Learning to use this instrument will make your flying easier in terms of performance and safety; it will enable you to improve your flying technique and make quicker piloting decisions thanks to the comprehensive flight information that is provided. Another benefit is the ability to download and analyze your flight data afterwards.

The instrument has been designed to allow for future software developments to be easily incorporated via the Internet.

Before you get started, make sure you have downloaded the free Digifly software for your AIR's management, **AirTools**, **AirPages** and **AirUpdater**, from our website www.digifly.com

DIGIFLY INTERNATIONAL GUARANTEE

Dear Customer,

Thank you for purchasing this Digifly product which has been designed and manufactured to the highest quality standards. Digifly warrants this product to be free from defects in materials and workmanship for 3 years from the date of purchase.

The Digifly guarantee applies provided the product is handled properly for its intended use, in accordance with its operating instructions and upon presentation of the original invoice or cash receipt, indicating the date of purchase, the dealer's name, the model and the serial number of the instrument.

The customer is however, responsible for any transportation costs. The unit must be securely packaged for return.

The Digifly guarantee may not apply if:

- The documents have been altered in any way or made illegible.
- Repairs or product modifications and alterations have been executed by unauthorized person or service.
- Damage is caused by accidents including but not limited to lightning, water or fire, misuse or neglect, or every malfunction not related to manufacturing defects of your instruments.

If your Digifly product is not working correctly or is defective, you must first contact your dealer, in order to avoid unnecessary inconvenience. Please do not send the instrument back before previous approval.



Digifly Offices

Corporate Headquarters

Digifly Europe Srl
Bologna
Italy
Phone : +39 370 1167217
Web : www.digifly.com
E-mail : info@digifly.com

North, Central and South American Headquarters

Digifly USA
St. Augustine, FL
USA
Phone : +1 (240) 343-5987
Web : www.digiflyusa.com
E-mail : flydigifly@gmail.com

1 INDEX

1	INDEX	3
2	GETTING STARTED	7
2.1	CONNECTIONS, SENSORS AND AIR MANAGEMENT SOFTWARE	7
2.2	BATTERY	8
2.2.1	BATTERY RECHARGE	8
2.2.2	EXTERNAL POWER SUPPLY	8
2.3	KEYBOARD - NORMAL OR LONG KEY PRESS	9
2.4	POWER ON & OFF	9
2.5	DISPLAY CONTRAST ADJUSTMENT	9
2.6	MENU	9
2.6.1	STANDARD FIELDS EDITING	10
2.6.2	ALPHANUMERICAL FIELDS EDITING	10
2.7	MULTI LANGUAGE HELP	10
2.8	RESTORE FACTORY SETTINGS	10
2.9	RESET	11
3	QUICK REFERENCE GUIDE	12
3.1	SYMBOLS	12
3.2	PAGES	13
3.2.1	CONFIGURABLE PAGES	13
3.2.2	MANUAL PAGE SWITCHING	14
3.2.3	AUTOMATIC PAGE SWITCHING (INTELLIFY)	14
3.3	COMPETITION PAGES	16
3.3.1	PAGE 1 COMP FLIGHT (THERMAL) AND PAGE 2 COMP FLIGHT (GLIDE)	16
3.3.2	PAGE 3 COMP START (THERMAL) AND PAGE 4 COMP START (GLIDE)	17
3.4	CROSS COUNTRY (XC) PAGES	18
3.4.1	PAGE 7 XC (THERMAL)	19
3.4.2	PAGE 8 XC (GLIDE)	20
3.5	PAGE 9 COMPASS	21
3.6	PAGE 10 RELAX	22
3.7	PAGE 11 GLIDE COMPUTER	23
3.8	PAG 12 MAP	24
3.9	PAGE 13 MASTER INFO GPS PAGE	25
3.9.1	GPS STATUS INFORMATION	26
3.9.2	LATITUDE & LONGITUDE COORDINATES	26
3.9.3	LATITUDE & LONGITUDE COORDINATES OPTIONS	26
3.9.4	GPS SIGNAL QUALITY	26
3.9.5	GPS ALTITUDE	26
3.9.6	GPS DIRECTION (TRK)	26
3.9.7	GPS GROUND SPEED	26
3.9.8	REAL TIME NAVIGATION MANAGER / SKIP WAYPOINT	26
3.9.9	CREATING A NEW WAYPOINT USING THE CURRENT POSITION (MARK)	27
3.9.10	NAVIGATION TO "HOME" WAYPOINT (GOTO HOME)	27
3.9.11	DEACTIVATING THE CURRENT NAVIGATION (CLEAR NAV)	27
3.9.12	DATE & TIME	27
4	MAIN FUNCTIONS	28
4.1	ALTIMETERS	28
4.1.1	AGL ALTIMETER	28
4.1.2	ALTIMETERS' SETTINGS	28
4.1.3	ALTIMETERS' SETTINGS	28
4.1.4	MAXIMUM ALTITUDE ALARM	29
4.2	VARIOMETERS	30
4.2.1	11-SENSORS VARIOMETER WITH SELF - ADAPTIVE SENSITIVITY	30
4.2.2	DIGITAL VARIO	30
4.2.3	ANALOGICAL VARIO	30
4.2.4	INTEGRATED (AVERAGE) VARIO	30

4.2.5	NET VARIO (WITH OPTIONAL PITOT TUBE).....	30
4.2.6	INTEGRATED VARIO / NET VARIO AUTOMATIC SWITCH	31
4.2.7	McCREADY (WITH OPTIONAL PITOT TUBE).....	31
4.2.8	EQUIVALENT McCREADY (WITH OPTIONAL PITOT TUBE)	31
4.2.9	TOTAL ENERGY COMPENSATION (WITH OPTIONAL PITOT TUBE).....	32
4.2.10	ACOUSTIC VARIO.....	33
4.2.11	ACOUSTIC VARIO PRE-THERMAL TONE	35
4.2.12	VARIO SIMULATOR.....	35
4.3	AIRSPPEED (WITH OPTIONAL PITOT TUBE)	36
4.3.1	SPEED TO FLY (WITH OPTIONAL PITOT TUBE).....	36
4.3.2	ACOUSTIC McCREADY (WITH OPTIONAL PITOT TUBE).....	37
4.3.3	SPEED DIFFERENCE (WITH OPTIONAL PITOT TUBE)	38
4.3.4	STALL ALARM (WITH OPTIONAL PITOT TUBE)	38
4.3.5	AIRSPPEED CALIBRATION (WITH OPTIONAL PITOT TUBE).....	38
4.4	POLAR (WITH OPTIONAL PITOT TUBE).....	39
4.5	BAROMETER.....	40
4.6	TIME	40
4.7	CHRONOGRAPH.....	40
4.8	PILOT'S NAME & GLIDER'S INFO	40
5	ADVANCED FUNCTIONS	41
5.1	SYNTHETIC INERTIAL PLATFORM	41
6	GPS FUNCTIONS.....	42
6.1	INTEGRATED GPS MULTI-CONSTELLATION RECEIVER WITH 99 CHANNELS	42
6.2	GPS STATUS INFORMATION.....	42
6.3	GPS SIGNAL QUALITY (HDOP)	42
6.4	EARTH MODEL USED FOR DISTANCE CALCULATION	42
6.5	TOLERANCE USED FOR DISTANCE CALCULATION	42
6.6	LATITUDE & LONGITUDE COORDINATES.....	42
6.7	LATITUDE & LONGITUDE COORDINATES OPTIONS	42
6.8	GPS ALTITUDE	42
6.9	GPS GROUND SPEED	42
6.10	GPS DIRECTION (TRK)	43
6.11	GROUND EFFICIENCY (GLIDE RATIO).....	43
6.12	WIND SPEED AND DIRECTION INDICATION USING GPS.....	43
6.13	LAST THERMAL POSITION, DISTANCE & HEIGHT INFORMATION.....	45
6.14	THERMAL ASSIST.....	45
6.15	THERMAL TUTOR.....	45
6.16	PLOTTER.....	46
6.17	MAP.....	47
6.17.1	TERRAIN (first layer):	47
6.17.2	NAV (second layer).....	50
6.17.3	FAI-TRANGLE ASSISTANT (third layer)	51
6.17.4	AIRSPACE CTR (fourth layer).....	52
6.18	3D AIRSPACE MANAGER (CTR).....	52
6.18.1	UPLOAD AND ENABLE AIRSPACE CTRs TO THE DIGIFLY AIR	52
6.18.2	VISUAL AND ACOUSTIC DISTANCE WARNING TO THE CTR	54
6.18.3	CTR's HORIZONTAL DISTANCE INDICATOR	54
6.18.4	CTR's VERTICAL DISTANCE INDICATOR.....	54
7	WAYPOINT MANAGEMENT	55
7.1	WAYPOINT DATABASES: COMPETITION & USER	55
7.1.1	MANUALLY CREATING A NEW WAYPOINT.....	55
7.1.2	CREATING A NEW WAYPOINT USING THE CURRENT POSITION (MARK).....	55
7.1.3	EDIT WAYPOINT.....	55
7.1.4	DELETE WAYPOINT	55
8	NAVIGATE TO A SINGLE WAYPOINT (GOTO).....	56
8.1	ACTIVATING NAVIGATION TO A WAYPOINT (GOTO)	56
8.1.1	NAVIGATION TO WAYPOINT HOME (GOTO HOME).....	56
8.1.2	NAVIGATION TO THE NEAREST LANDING ZONE (GOTO LANDING).....	56

8.1.3	NAVIGATION TO THE NEAREST WAYPOINT (GOTO NEAREST)	56
8.1.4	NAVIGATION TO A GENERIC WAYPOINT (GOTO).....	57
8.1.5	DEACTIVATING NAVIGATION TO A WAYPOINT (CLEAR NAV)	57
8.2	NAVIGATION FUNCTIONS TO A SINGLE WAYPOINT (GOTO)	58
8.2.1	DIRECTION , DISTANCE , EXPECTED GLIDE RATIO & HEIGHT TO THE CURRENT WAYPOINT.....	58
8.2.2	COMPASS TO THE CURRENT WAYPOINT.....	59
8.2.3	REQUIRED GLIDE RATIO TO THE CURRENT WAYPOINT.....	59
8.2.4	ARRIVAL HOUR, ARRIVAL TIME TO THE CURRENT WAYPOINT.....	59
8.2.5	HSI GRAPHIC INDICATION IN SINGLE WAYPOINT MODE (GOTO).....	59
9	ROUTE MANAGEMENT	60
9.1	ROUTES OVERVIEW	60
9.2	VISUALIZING WAYPOINT INFO OF A ROUTE.....	60
9.3	INSERT A WAYPOINT IN A ROUTE	60
9.4	SUBSTITUTING A WAYPOINT IN A ROUTE	60
9.5	MODIFY A WAYPOINT IN A ROUTE (PARAMETER CHANGE).....	61
9.6	DELETE A WAYPOINT OF A ROUTE	62
9.7	DELETING A ROUTE.....	62
10	ROUTE NAVIGATION.....	63
10.1	ACTIVATING A ROUTE	63
10.2	DE-ACTIVATING A ROUTE (CLEAR NAV).....	63
10.3	OPTIMIZED NAVIGATION.....	63
10.4	NAVIGATION TO A STANDARD WAYPOINT	64
10.4.1	DIRECTION , DISTANCE , EXPECTED GLIDE RATIO & HEIGHT OVER THE CURRENT WAYPOINT.....	64
10.4.2	COMPASS TO THE CURRENT WAYPOINT.....	65
10.4.3	REQUIRED GLIDE RATIO TO CURRENT WAYPOINT.....	65
10.4.4	ARRIVAL TIME & TIME TO CURRENT WAYPOINT	65
10.4.5	HSI GRAPHIC INDICATION IN ROUTE MODE	65
10.4.6	DISTANCE , EXPECTED GLIDE RATIO & HEIGHT OVER THE ARRIVAL WAYPOINT (GOAL)	66
10.4.7	REQUIRED GLIDE RATIO TO GOAL.....	66
10.4.8	ARRIVAL TIME & TIME TO GOAL	66
10.4.9	CROSS TRACK ERROR (XT).....	66
10.5	NAVIGATION TO THE START WAYPOINT (GATE)	67
10.5.1	STARTING TIME (TSTART).....	68
10.5.2	REMAINING TIME TO START (CSTART)	68
10.5.3	EXPECTED ARRIVAL TIME TO START LINE (ESTART).....	68
10.5.4	REQUIRED SPEED TO START THE CYLINDER LINE (STS).....	68
10.5.5	CHOOSING A DIFFERENT START GATE TIME IN A COMPETITION ROUTE.....	68
10.6	SKIP WAYPOINT SHORTCUT.....	68
10.7	OPERATION CHECKLIST BEFORE A TASK	69
11	FLIGHT RECORDER.....	70
11.1	ACTIVATING / DE-ACTIVATING THE FLIGHT RECORDER	70
11.1.1	RECORDING MODE: AUTOMATIC START "AUT"	70
11.1.2	RECORDING MODE: ALWAYS ACTIVE "ALW"	70
11.1.3	RECORDING MODE "OFF"	70
11.2	RECORDING RATE.....	71
11.3	LOG BOOK MANAGEMENT (LOG BOOK)	71
11.4	INTEGRATED IGC FILE.....	71
12	ADDITIONAL MEMORY CARD.....	72
12.1	MICRO SD MANAGER.....	72
13	CONNECTIONS & INTERFACES	74
13.1	USB CABLE CONNECTION.....	74
13.2	BLUETOOTH CONNECTION.....	76
13.2.1	BLUETOOTH SPP (Bluetooth Classic) "PAIRING"	77
14	SOFTWARE.....	78
14.1	AIR MANAGEMENT SOFTWARE.....	78
14.1.1	DIGIFLY AIRTOOLS SOFTWARE (PC / Mac).....	78

14.1.2	DIGIFLY AIRPAGES SOFTWARE (PC / Mac)	79
14.1.3	GPSDUMP SOFTWARE (PC, Mac, ANDROID)	82
14.2	DIGIFLY AIRUPDATER SOFTWARE FOR FIRMWARE UPDATE (PC, Mac)	85
14.2.1	FIRMWARE UPDATE PROCEDURE	85
14.3	FLIGHT PLAYBACK SIMULATOR COMPATIBLE WITH CONDOR SIMULATOR	87
15	LIVE TELEMETRY WITH THE INTEGRATED DIGI-FLYBOX	88
15.1	ACTIVATING THE DIGIFLY'S TELEMETRY DATA OUTPUT Digi-FLYBox	88
15.1.1	Digi-FLYBOX TELEMETRY GPS DATA SELECTION	90
15.1.2	Digi-FLYBOX TELEMETRY AIRDATA TYPE SELECTION	91
15.1.3	Digi-FLYBOX TELEMETRY AIRDATA FREQUENCY SELECTION	91
15.2	DIGI-FLYBOX TELEMETRY TO LK8000	92
15.3	DIGI-FLYBOX TELEMETRY TO XCSoAR	95
15.4	DIGI-FLYBOX TELEMETRY TO XTRACK	97
15.5	DIGI-FLYBOX TELEMETRY TO TOPHAT	100
15.6	DIGI-FLYBOX LIVE TRACK & TELEMETRY TO GPSDUMP	102
15.7	DIGI-FLYBOX LIVE TRACK & TELEMETRY TO TTLIVETRACK24	104
15.8	DIGI-FLYBOX LIVE TRACK & TELEMETRY TO FLYSKYHY	106
15.9	TELEMETRY BIDIRECTIONAL COMMANDS	108
16	APPENDIX	109
16.1	DIGIFLY AIR STANDARD ACCESSORIES	109
16.2	OPTIONAL ACCESSORIES	109
16.3	TECHNICAL FEATURES	109
16.3.1	STANDARD FUNCTIONS	109
16.3.2	ADVANCED FUNCTIONS	110
16.3.3	GPS FUNCTIONS	110
16.3.4	GENERAL SPECIFICATIONS	110
16.4	MAIN SET UP PARAMETERS	112
16.5	VARIOMETER SETUP PARAMETERS	113
16.6	ADVANCED SETUP PARAMETERS	114
16.7	GLIDE COMPUTER SETUP PARAMETERS	115

2 GETTING STARTED

2.1 CONNECTIONS, SENSORS and AIR MANAGEMENT SOFTWARE

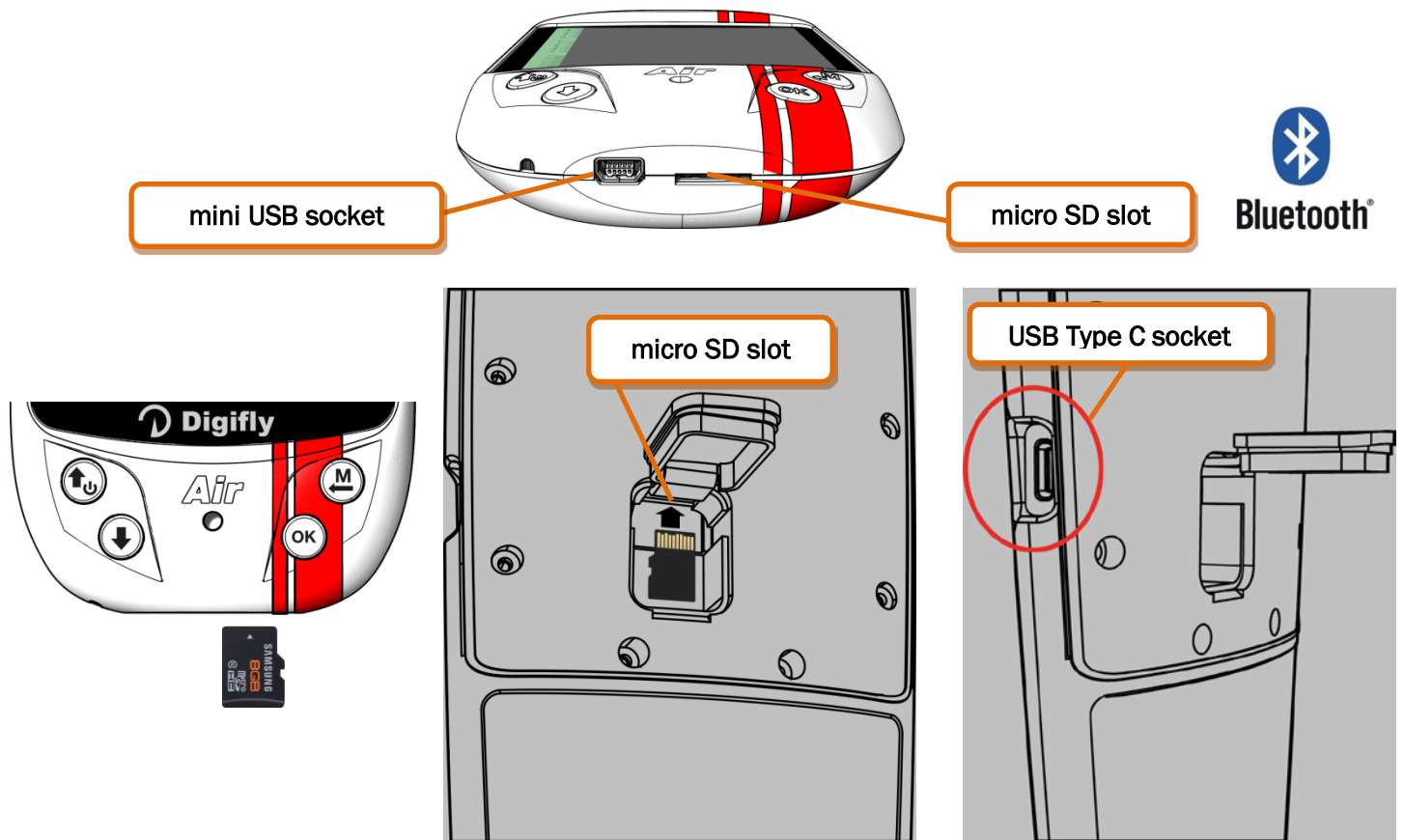

▪ Main Features :

- Dual purpose mini USB (or Type C in the Air-HG model) socket allows the Digifly AIR to be recharged with any standard USB 5v charger and, additionally, to be connected to a personal computer or Mac for configuration & flight data management.
- Micro SD card slot; use Class 10 cards with 8 to 32GB formatted FAT32.
- Bluetooth System Dual Mode SPP / BLE for wireless communication with other electronic devices
- Integrated Digi-FlyBox to send its Telemetry to another electronic device, via USB cable or via Bluetooth. This means sending the information from its sensors through a wireless communication system.
- GPS receiver 99 channels Multi-constellation
- Barometer (atmospheric pressure sensor)
- Integrated anemometer – pitot tube (optional)
- 3-axis synthetic inertial platform.
- 3-axis synthetic compass
- 3-axis synthetic accelerometer
- Free digital worldwide topographic maps.
- Airspace upload and management.
- Three Free management software programs both for PC or Mac: AirTools, AirPages and AirUpdater.
- **Optional Features:** Integrated anemometer – Pitot Tube System

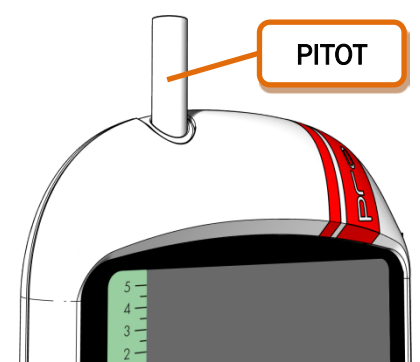

2.2 BATTERY

- The main power is supplied by an internal rechargeable high capacity lithium battery, which has no memory effect, so it can be partially recharged, without affecting the battery's life. It also has a very low self-discharge rate (about six months) and works very well at low temperatures. A fully charged battery will power the instrument for over 20 hours: when the battery icon starts to flash, you have approximately 4 hours left of battery power.
- Make sure your instrument is fully charged any time you put store it for a longer period of time (e.g. end of the flying season) or any time you know you won't be using it for a while.
- To avoid permanent battery damage, you must ensure that it receives a full charge within 3 months of the last full charge.

2.2.1 BATTERY RECHARGE

- To recharge the instrument, connect the USB cable to a standard USB charger.
- Input: DC 5v is required and a 1A is recommended.
- The required time for a full charge is about 8 hours.
- There are no problems if you leave the vario charging for more than 8 hours, as the vario automatically switches to a "maintain mode" preventing the battery from being overcharged.
- The Digifly AIR's lithium battery has no "memory effect", so it can be also partially charged.

2.2.2 EXTERNAL POWER SUPPLY







- The mini USB socket can be used to power the instrument and simultaneously charge the internal battery.
- An external stabilized 5VDC power supply (e.g. a solar panel, external power bank, etc.) with a minimum of 150mA is necessary to turn the instrument on; any excess power will be used to charge the internal lithium battery. Proper solar panels are suitable to power the instrument.
- **Important Notice:** do not keep your Digifly AIR connected to its USB port in flight or in any situation where the USB cable could create an undesired movement to the charging port, applying force on the soldered connection of the mini USB, resulting in its detachment from the board. This also applies when you carry your AIR in your harness or a backpack: do not have the USB cable connected to it.

2.3 KEYBOARD - NORMAL OR LONG KEY PRESS





- The time length you keep the keys pressed on your Digifly instrument selects the available functions.
- For a **normal press**: press the button for less than a second
- For a **LONG PRESS**: keep the button pressed down for at least 2 seconds

Note: When not specified, the key press has to be considered as a normal key press (less than a second).





2.4 POWER ON & OFF

- In order to avoid that your Digifly unintentionally turns on, we have updated the power on process adding a secondary confirmation step:
 - 1) The instrument must have been on OFF mode for at least 5 seconds
 - 2) Long press the ON button  for at least 5 consecutive seconds
 - 3) A “PRESS OK TO POWER ON” message will come up on the screen
 - 4) Release the power ON button 
 - 5) Press the  button within 6 seconds to confirm; otherwise, the instrument will automatically turn itself back off
- Note: By keeping the  button pressed when you confirm power on, the launch screen will be displayed for as long as you keep the button down
- To **turn** your Digifly AIR **off**, press the  key for at least 4 seconds, until you hear it “beep”. If the logger is recording, you will be prompted to confirm your choice by pressing the  key or, to cancel, press the  key; it will automatically cancel the request within 3 seconds of no input.

2.5 DISPLAY CONTRAST ADJUSTMENT









- To change the contrast of the display, press the  key to enter the “MAIN SETUP” menu, select CTRS (MAIN SETUP \ n. 1 CTRS), go to the edit mode pressing the  key, set the preferred contrast using the keys: ‘arrow UP’  or ‘arrow DOWN’ , then save the changes by pressing the  key.

2.6 MENU









- To navigate the menus of your instrument, press the  key (“MENU” function).
- To select the sub-menus, scroll UP or DOWN the list using the   arrow keys, then confirm your choice pressing the  key (“ENT” function).
- To exit and get back to the main screen press the  key (“ESC” function).

MENU
Wpt Near Airfield
Wpt Nearest
Wpt Competition
Wpt User
Routes
Altimeters
Logbook
AirTools
Main Setup
Variometer Setup
Advanced Setup
Glide Computer Setup
MicroSD Manager
Start Telemetry BT

2.6.1 STANDARD FIELDS EDITING

- To change parameters and settings, select the parameter you want to change by scrolling UP or DOWN using the   keys, press the  key (“EDIT” function) to enter in the edit mode.
- To change the value of the selected parameter, use the   keys to select the new value, each parameter’s change is automatically saved (“AUTOSAVE” function) when you exit; keeping the ,  keys pressed activates the quick parameter change (“AUTOREPEAT”) function.
- To exit from the edit function, press the  key (“ESC” function).

2.6.2 ALPHANUMERICAL FIELDS EDITING

- Changing the alphanumerical fields is different from the normal editing described above, because it is possible to modify every single character of the field.
- To modify the field, press the  key (“EDIT” function) that activates the edit mode.
- Use the arrow keys   to change the character shown in reverse mode on the display. Each parameter’s change is automatically saved (“AUTOSAVE” function) when you exit; a LONG PRESS of the arrow keys activates the quick parameter change (“AUTOREPEAT”) function. Pressing  will take you straight to the alphabet.
- By pressing the  key, you will shift to the character on the right and edit it; by pressing the  key repeatedly you will scroll towards the right through all the individual fields until you go back to the first one. A LONG PRESS of the  key moves back to the left; to exit press the  key.



2.7 MULTI LANGUAGE HELP

- “Help” texts are available in the setup menus to guide you through the parameters. It is possible to set a language for these texts on the MAIN SETUP menu (**MAIN SETUP \ n. 2 LANG**) by selecting the preferred language. The change will be automatically saved when you exit.

Another option is for you to create your own files using AirTools, save it and then upload it to the instrument. You cannot upload one single line at a time, you upload all the helps contained in a menu (Main, Advanced or Variometer).

Important: after every firmware update, it is necessary to update the help file containing the help messages as well. The help file update can be performed from your PC/Mac using Digify AirTools, function: “upload HELP” or using the microSD (Main Menu / microSD Manager / Auto Import) (see 12.1).



2.8 RESTORE FACTORY SETTINGS

- To restore the factory settings (default values for all parameters) :
 - 1) The instrument must have been on OFF mode for at least 5 seconds
 - 2) Press the power ON button 
 - 3) You will see the “PRESS OK TO POWER ON” message on the screen
 - 4) While keeping the power ON button  down, press the  button at the same time
 - 5) Keep both buttons pressed until you see the “Factory Set ?” appear
 - 6) Release both buttons

7) To confirm a factory settings reset, you need to press the  button within a max. of 5 seconds











8) Otherwise, to cancel the operation, press the  button or wait more than 5 seconds for the operation to cancel automatically

2.9 RESET

- If a system crash occurs (resulting in the instrument freezing), press the  (arrow down) and the  (power) buttons at the same time for at least 5 seconds; this will force the instrument to turn off and reset, then turn your instrument back on normally. This reset will **not** erase any data or settings from your instrument.

3 QUICK REFERENCE GUIDE

3.1 SYMBOLS

	Battery level
	Bluetooth activated
	Static icon = GPS FIX valid (GPS position available) Blinking icon = low GPS signal (GPS position NOT available)
	Flight recorder on
	Volume level
	Direction towards the center of the current Waypoint
	Direction towards the optimized point of the current WP's cylinder
	Direction towards the optimized point of the current WP's cylinder
	Last thermal position
	Wind direction (from where it is coming)

3.2 PAGES

- The Digifly AIR features 13 pages: 12 configurable pages and one main page with GPS info, called the “**MASTER INFO GPS PAGE**” which, for safety reasons, cannot be changed or disabled.

3.2.1 CONFIGURABLE PAGES

- There are 12 configurable pages; each one is linked to one of the 12 configurable parameters (from **MAIN SETUP\ n. 15 PG01** till **MAIN SETUP\ n. 26 PG12**) and for each page it is possible to configure a different layout:
OFF = the layout view of the page is disabled (the page will be skipped)
STD = it will show the corresponding Digifly standard layout
USR = it will show the corresponding user layout created and uploaded by the user using the **free** Digifly program **AirPages** (for more details about software usage refer to chapter 14.1.2).



▪ REFERENCE TO NAME AND CONTENT OF CUSTOMIZABLE PAGES

- PG01 page_1_IntelliComp_flight_thermal **OFF**/STD/USR
- PG02 page_2_IntelliComp_flight_glide **OFF**/STD/USR
- PG03 page_3_IntelliComp_start_thermal **OFF**/STD/USR
- PG04 page_4_IntelliComp_start_glide **OFF**/STD/USR
- PG05 page_5 **OFF**/USR
- PG06 page_6 **OFF**/USR
- PG07 page_7_IntelliXc_cross_thermal **OFF**/STD/USR
- PG08 **page_8_IntelliXc_cross_glide** **OFF**/STD/USR
- PG09 page_9_compass **OFF**/STD/USR
- PG10 page_10_relax **OFF**/STD/USR
- PG11 page_11 Glide Computer **OFF**/STD/USR
- PG12 page_12_map **OFF**/STD/USR

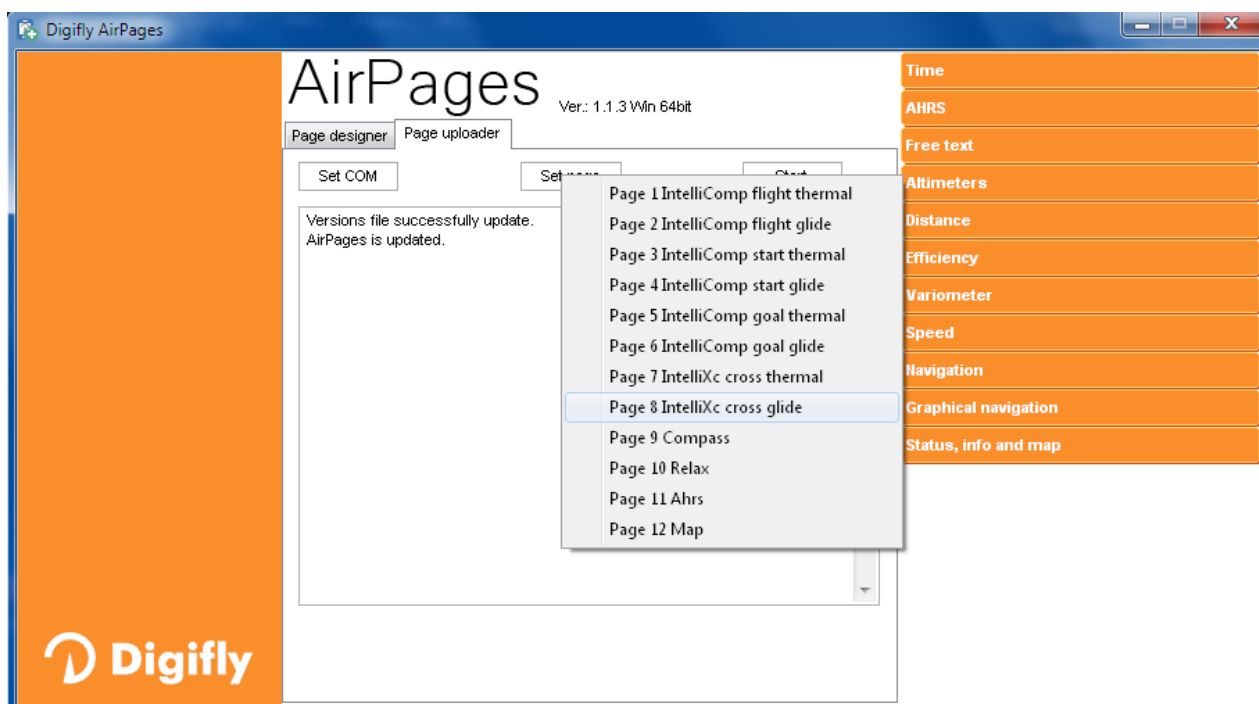
Default page settings (in bold type) : PG1=OFF, PG2=OFF, PG3=OFF, PG4=OFF, PG5=OFF, PG6=OFF, PG7=STD, PG8=STD, PG9=STD, PG10=STD, PG11=STD, PG12=STD



3.2.2 MANUAL PAGE SWITCHING

- To manually change the pages, press the  key to go forward or the  key to go back.
You can manually switch pages even if you are in “Intellify” mode.

3.2.3 AUTOMATIC PAGE SWITCHING (INTELLIFY)

- The automatic page-switching among the different pages is automatically managed by the **Intellify** system, which recognizes the type of in-flight situation you are in at all times.
- Each type of in-flight situation is associated to a different set of pages (2 per set):
Pages 1 and 2 are associated to a “Competition flying while navigating towards a standard waypoint” situation.;
Pages 3 and 4 are associated to a “Competition flying while navigating towards a Start waypoint”;
Pages 7 and 8 are associated to a “Free Cross Country flying” situation;
- Each set of pages is formed by a “THERMAL” and a “GLIDE” version. The automatic page switching within each set of pages follows these criteria: It will switch to the “THERMAL” page when it notices a thermal that lasts longer than the value set on the **GLIDE COMPUTER SETUP \ n. 4 THET** parameter (default setting 2 seconds) and you make a turn to fly into it; it will switch to the “GLIDE” page when you fly “straight” for a period of time, longer than the value set on the **GLIDE COMPUTER SETUP \ n. 3 CRUT** (default setting 15 seconds).
- The **MAIN SETUP \ n. 27 IFLY** parameter sets the mode in which the Intellify system will work :
 - **IFLY=OFF**: automatic page switching is disabled.
 - **IFLY=XCM**:
automatic page switching will be on “Cross Country” mode (default setting): it will automatically switch between PG07 e PG08.
PG07 is the XC – Thermal page and PG08 is the XC – Glide page.
If I manually switch to a page different from PG07 or PG08, the automatic page switching mode will be paused until I manually switch back to a page among PG07 or PG08.
Remember to check that the 2 Cross Country pages are active: **MAIN SETUP \ n.21 PG07** and **MAIN SETUP \ n.22 PG08** on **STD** or **USR** (in case you have uploaded your own pages).
 - **IFLY=XCA (default) : (this is the recommended setting for a “Cross Country” flight)**
automatic page switching will be on “Cross Country” mode (default setting): it will automatically switch between PG07 e PG08.
PG07 is the XC – Thermal page and PG08 is the XC – Glide page.
If I manually switch to a page different from PG07 or PG08, the automatic page switching mode will be paused until I manually switch back to a page among PG07 or PG08.
N.B. In this mode, pages 7 and 8 are forcibly activated while pages 1,2,3,4 are forcibly deactivated.

- **IFLY=CPM:**

automatic page switching is in “Competition” mode:

when your current wpt is a standard one, it will automatically switch between PG01 and PG02;

when your current wpt is the START, it will automatically switch between PG03 and PG04.

If I manually switch to a page outside the PG01-PG04 range, while on IFLY = CMP mode, the automatic switching will be paused until I manually switch back to one of the pages of the PG01-PG04 range.

Remember to verify that all 4 competition pages are active: **MAIN SETUP\ n.15 PG01** to **MAIN SETUP\ n.18 PG06 = STD** or **USR** (in case you have uploaded your own pages).

- **IFLY=CPA: (this is the recommended setting for competitions)**

automatic page switching is in “Competition” mode:

when your current wpt is a standard one, it will automatically switch between PG01 and PG02;

when your current wpt is the START, it will automatically switch between PG03 and PG04.

If I manually switch to a page outside the PG01-PG04 range, while on IFLY = CMP mode, the automatic switching will be paused until I manually switch back to one of the pages of the PG01-PG04 range.

N.B. In this mode, pages 1,2,3,4 are forcibly activated while pages 7 and 8 are forcibly deactivated.

3.3 COMPETITION PAGES

- Pages 1-4 are designed for competition flying:
 - pages 1 and 2 provide information regarding navigation towards a standard waypoint;
 - pages 3 and 4 provide information regarding navigation towards the START;
- N.B. Pages 1 to 4 are disabled by default, to activate them automatically it is necessary to set the IFLY = CPA mode or to activate them manually you must set their 4 parameters (MAIN SETUP\ n. 15 PG01 to MAIN SETUP\ n. 18 PG04) to STD (to display the standard page your Digifly comes with) or on USR (to display the custom pages called "USER" previously uploaded to the Digifly using our free software AirPages).

3.3.1 PAGE 1 COMP FLIGHT (THERMAL) AND PAGE 2 COMP FLIGHT (GLIDE)

- Pages 1 and 2 provide information regarding navigation toward a standard waypoint:
 - your current waypoint's name
 - flight direction towards the optimized point of the current waypoint's cylinder(FOLLOW ME)
 - required glide to reach the optimized point of your current waypoint's cylinder
 - shortest distance to the current's waypoint cylinder (D0)
 - distance to the optimized point of the current waypoint's cylinder (D1)
 - Required glide to reach the cylinder of the route's last waypoint (GOAL)
 - Distance to the cylinder of the route's last waypoint (GOAL) (DA)
 - Estimated arrival height over the cylinder of the route's last waypoint (GOAL) (HA)
- When the instrument recognizes a thermal and you make a turn to fly into it, the automatic page switching feature will take you to PG01 COMP FLIGHT (THERMAL), which besides the navigation info will also display the information regarding the thermal itself: Thermal Assist will help you center the thermal's core better and (DT) will show you the distance to the thermal's core.
- When flying "on a straight line" for a period of time greater to the value set in the GLIDE COMPUTER SETUP \ n. 3 CRUT parameter (default 15sec) the instrument will automatically switch to PG02 COMP FLIGHT (GLIDE)

PAGE 1 COMP FLIGHT (THERMAL)

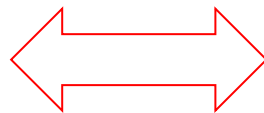

PAGE 2 COMP FLIGHT (GLIDE)

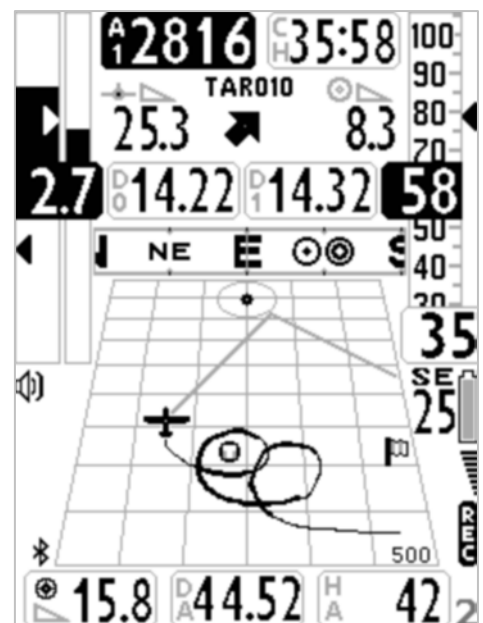

3.3.2 PAGE 3 COMP START (THERMAL) AND PAGE 4 COMP START (GLIDE)

- Pages 3 and 4 provide information regarding the navigation towards the START Waypoint of your route:
 - Current waypoint's name
 - Flight direction towards the optimized point of the current waypoint's cylinder (**FOLLOW ME**)
 - Required glide ratio to reach the optimized point on the current waypoint's cylinder
 - Required speed to reach to the Start line (cylinder) exactly at the Start Gate's opening time (**SS**)
 - Shortest distance to the nearest point on the current waypoint's cylinder (**D0**)
 - Distance to the optimized point on the current waypoint's cylinder (**D1**)
 - Current time (**RT**)
 - Time remaining (countdown) to the Start Gate opening time (**CS**)
 - Approximate time of arrival to the cylinder line of the Start waypoint I (**ES**)
- When the Digifly recognizes a thermal and you make a turn to fly into it, the Digifly will automatically switch to PG03 (**THERMAL**), which besides the navigation information, will also display the **Thermal Assist** instrument for thermal core centering.
- When you fly "on a straight line for a period of time greater than the value set on the **GLIDE COMPUTER SETUP \ n. 3 CRUT parameter** (default 15sec), the instrument will automatically switch to PG04 **COMP START (GLIDE)**

PAGE 3 COMP START THERMAL



PAGE 4 COMP START GLIDE

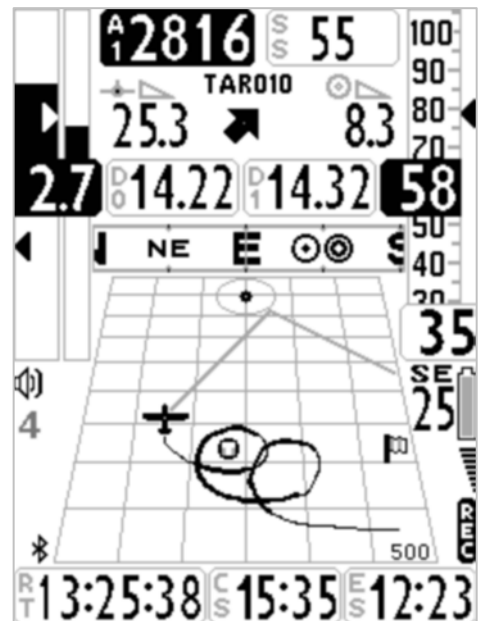

3.4 CROSS COUNTRY (XC) PAGES

- Pages 7 and 8 provide information regarding navigation during Cross Country (XC) flying and provides information regarding navigation towards the active waypoint:
 - Flight direction to reach the active waypoint
 - Required glide to reach the active waypoint's cylinder
 - Distance to the active waypoint (**D1**)
 - Estimated height at arrival to the active waypoint's cylinder (**H1**)
- When the Digifly recognizes a thermal and you make a turn to fly into it, the Digifly will automatically switch to **PG07XC (THERMAL)**, which besides the navigation information, will also display the instruments for thermal flying: **Thermal Assist** will help you center the thermal's core better and (DT) will show you the distance to the thermal's core.
- When you fly "on a straight line for a period of time greater than the value set on the **GLIDE COMPUTER SETUP \ n. 3 CRUT parameter** (default 15sec) the instrument will automatically switch to **PAGE08 XC (GLIDE)**

PAGE 7 XC (THERMAL)



PAGE 8 XC (GLIDE)

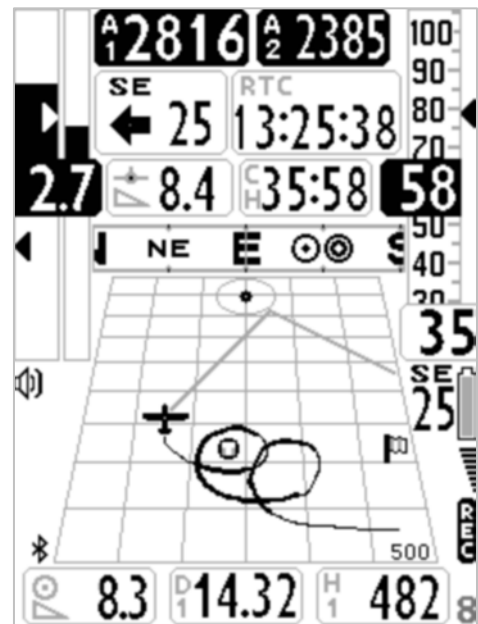

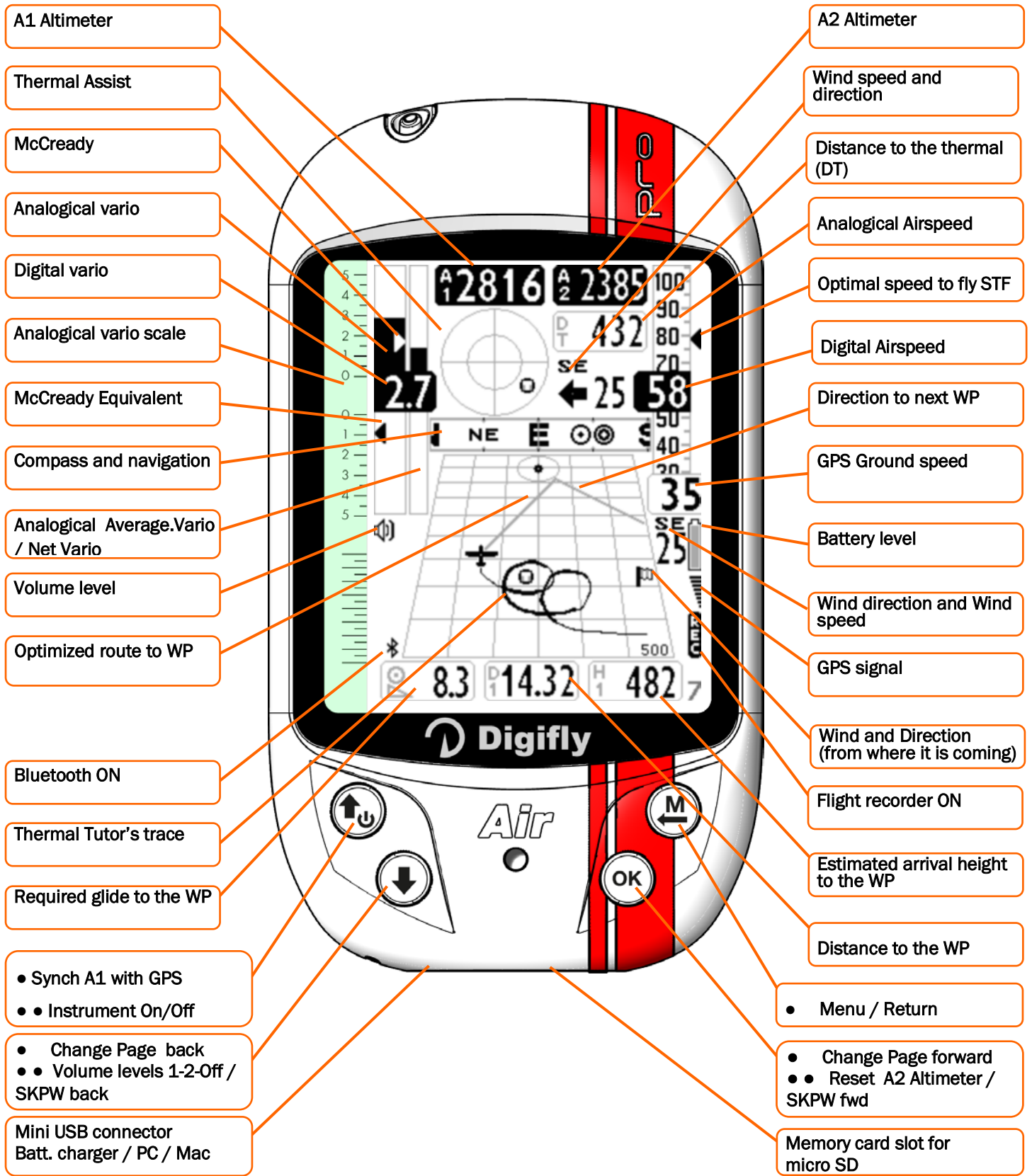

• = Normal key pressure • • = Long key pressure (2 seconds)

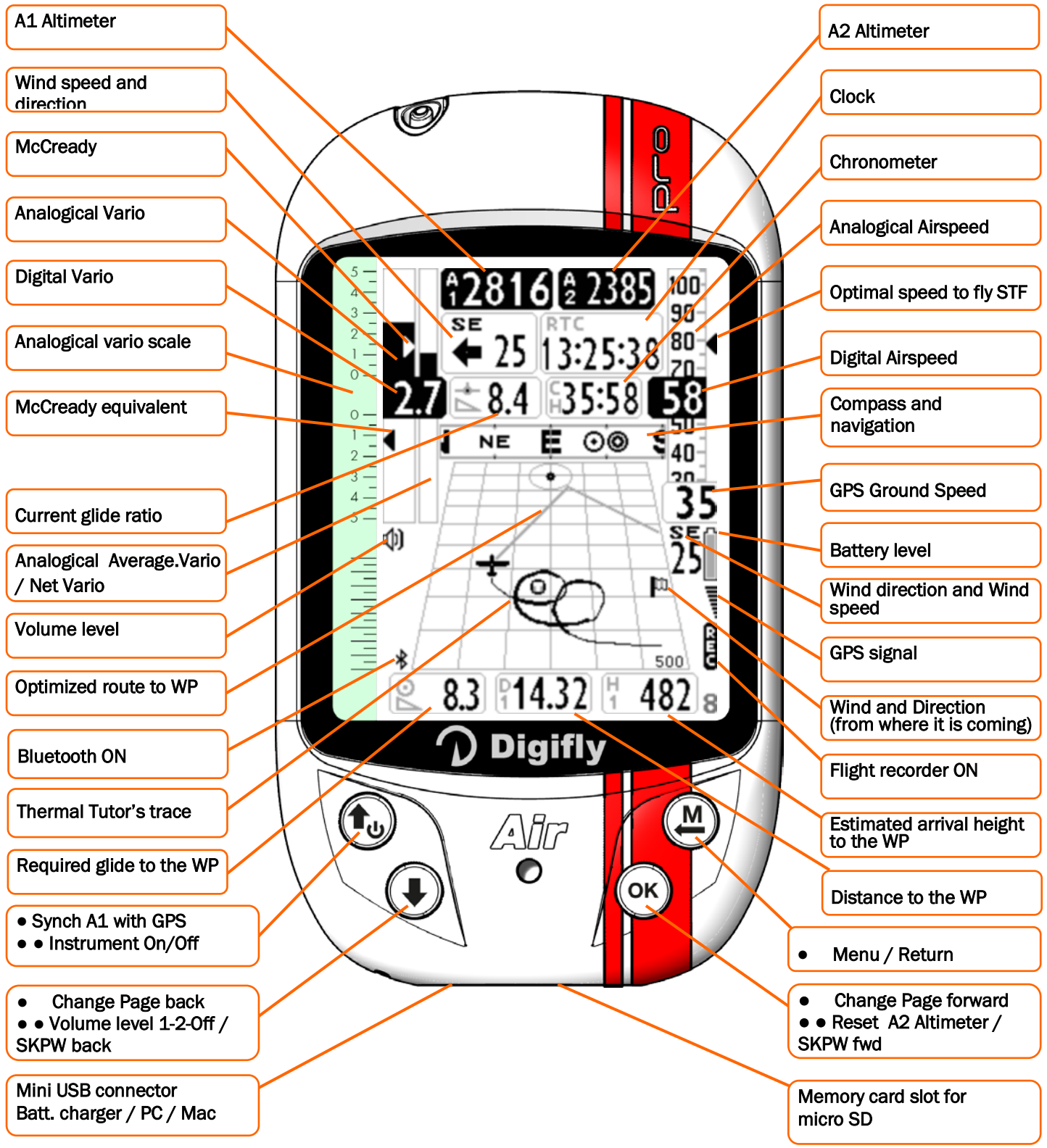

● = Normal key pressure ●● = Long key pressure (2 seconds)

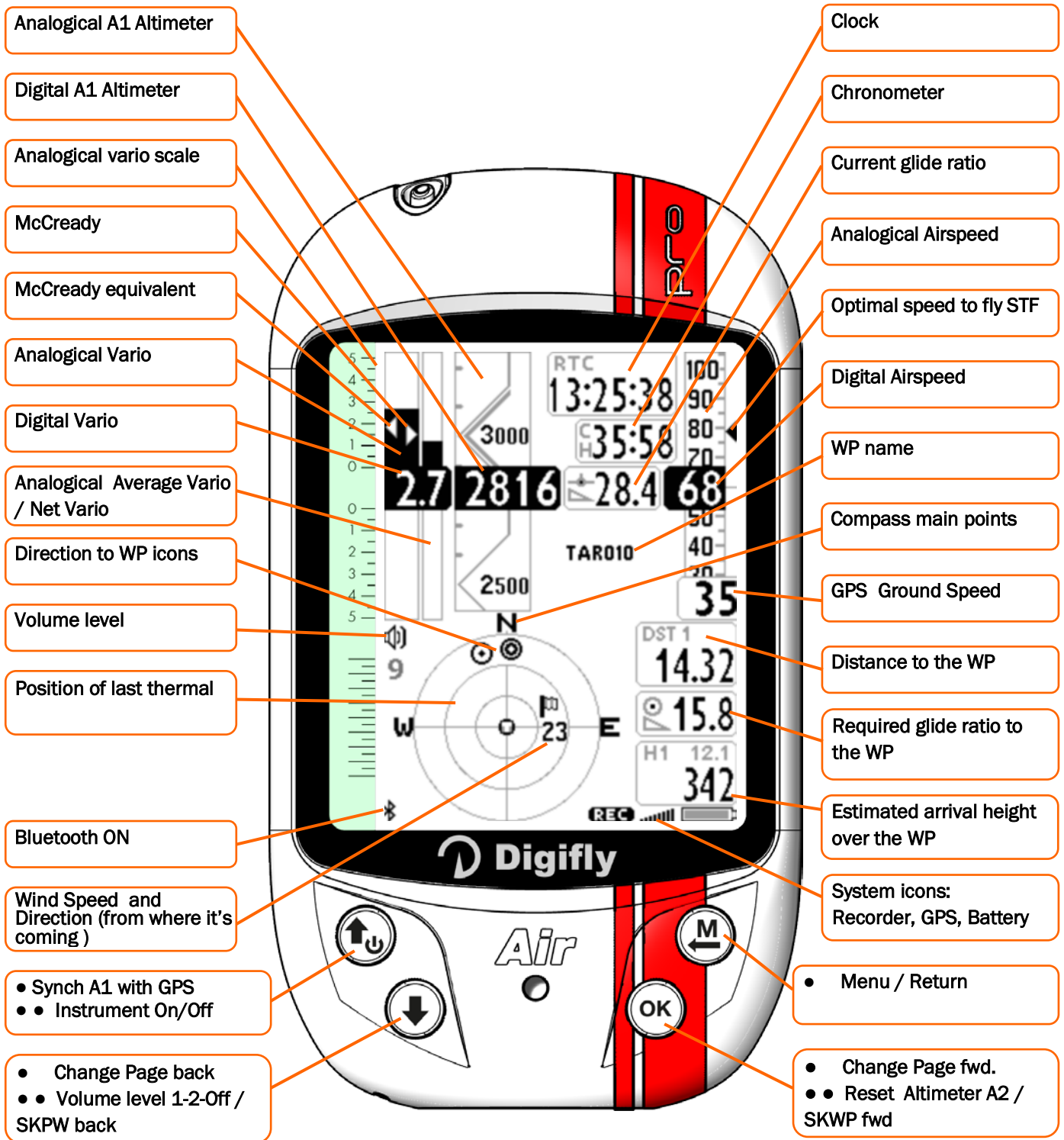

• = Normal key pressure •• = Long key pressure (2 seconds)

3.6 PAGE 10 RELAX

- Page 10 "RELAX" displays the most important information in very LARGE font size:
A1 barometric altimeter, Current glide ratio, Distance to the thermal, Thermal Assist, Wind speed and direction, GPS ground speed, Digital Airspeed, Variometer , Navigation compass and the Pitot offset value.

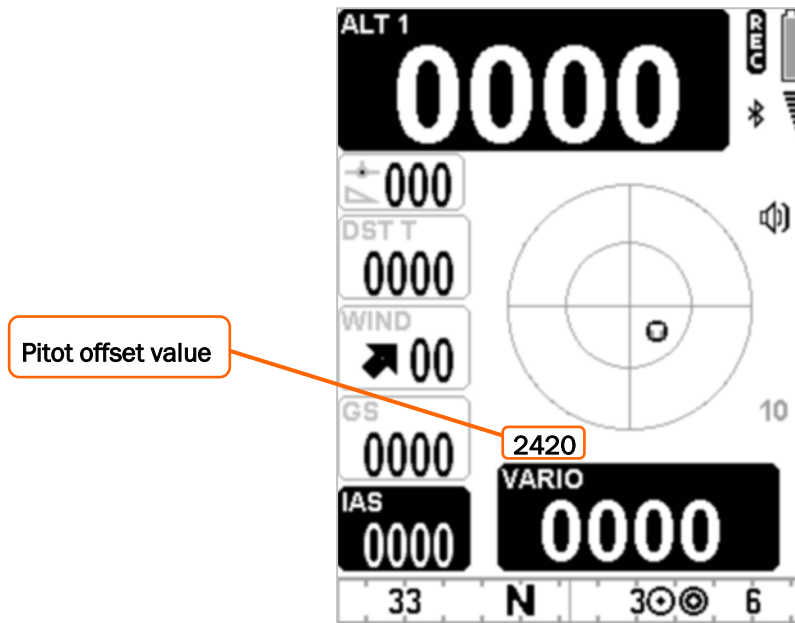

3.7 PAGE 11 GLIDE COMPUTER

- Page 11 "Glide Computer" displays, from top to bottom, the following parameters:

- Polar data** : if one of the polar is active, it will be continuously recalculated in real time and displayed on the top of this page:
 - Best efficiency value (**L/D max eff**)
 - Speed in km/h at max. efficiency (**speed max eff**)
 - Descending rate at max. efficiency (**m/s max eff**)

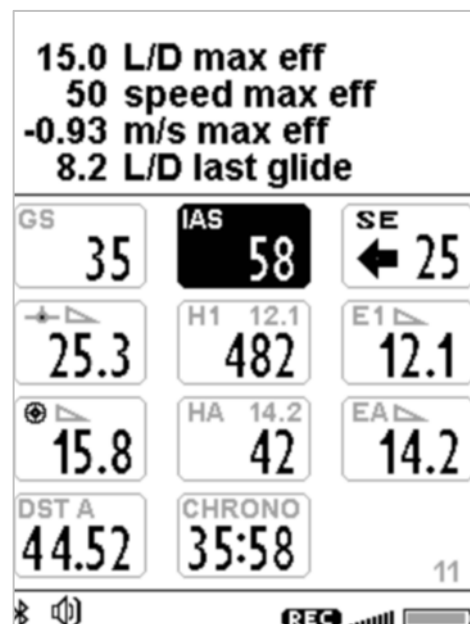

- L/D last glide** : shows the last previously stored average ground glide ratio. The parameter **GLIDE COMPUTER SETUP \ n. 12 EFFA** sets the time to be used to calculate this average.
- GPS ground speed
- Digital Airspeed
- Wind speed and direction
- Current glide ratio
- H1** : Estimated height above the goal , along the optimized route (see paragraph 10.4.1 for more details)
- E1** : (see paragraph 10.4.1 for more details)
- Required glide to reach the cylinder of the route's last waypoint (GOAL)
- HA** : Estimated arrival height over the cylinder of the route's last waypoint (GOAL) (see paragraph 10.4.6 for more details)
- EA** : (see paragraph 10.4.6 for more details)
- Distance to the cylinder of the route's last waypoint (GOAL)
- Chronometer

3.8 PAG 12 MAP

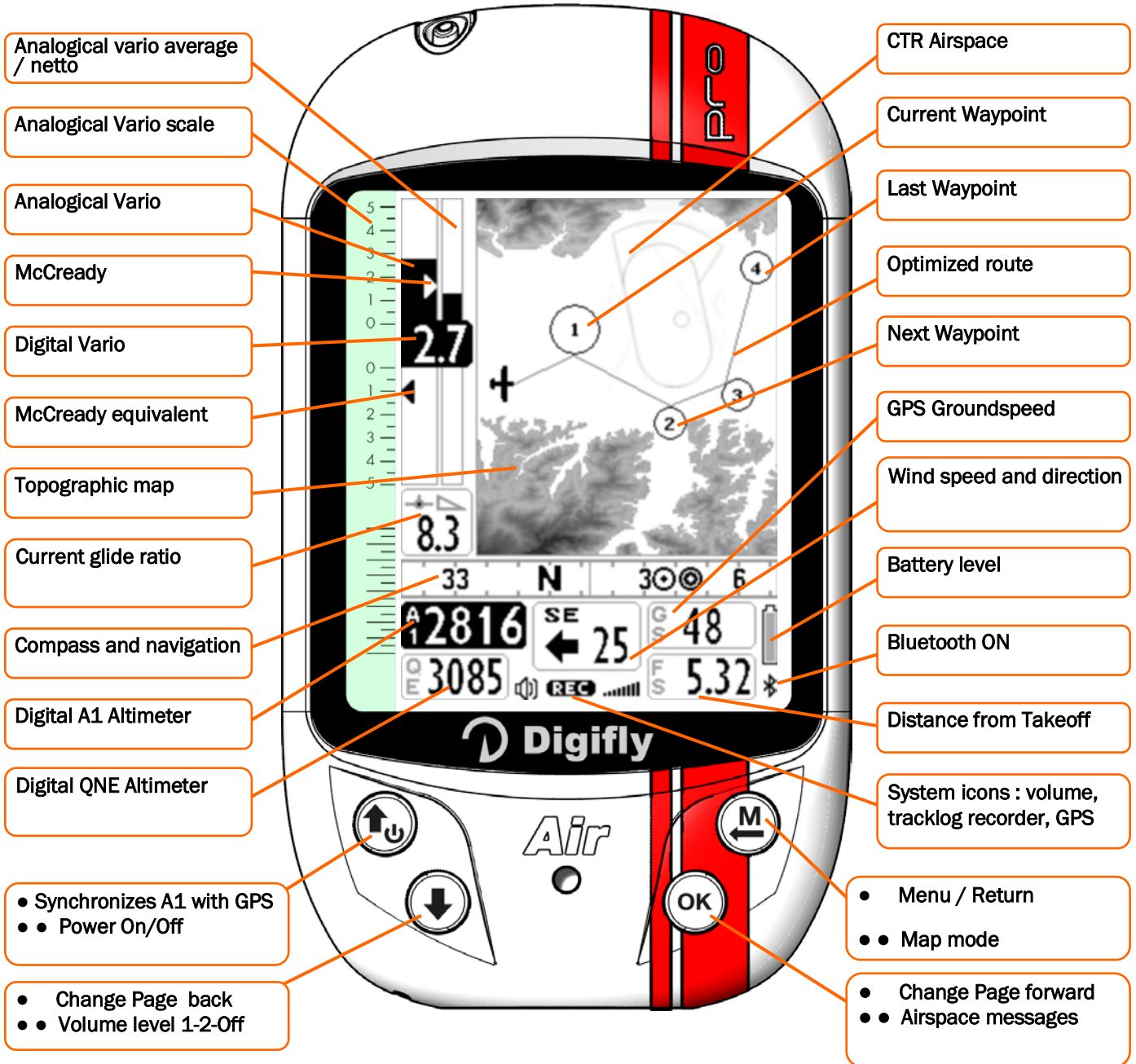

• = Normal •• = LONG press (2 seconds)

3.9 PAGE 13 MASTER INFO GPS PAGE

- On the MASTER INFO GPS page, all values relative to your GPS position and navigation are visible. While on this page only, you can access the following particular functions: “take me here” (GOTO HOME), “save current position” (MARK), “cancel current navigation” (CLEAR NAV), real time navigation supervision "Real Time Navigation Manager" of active route and “Skip Waypoint” through WPT.

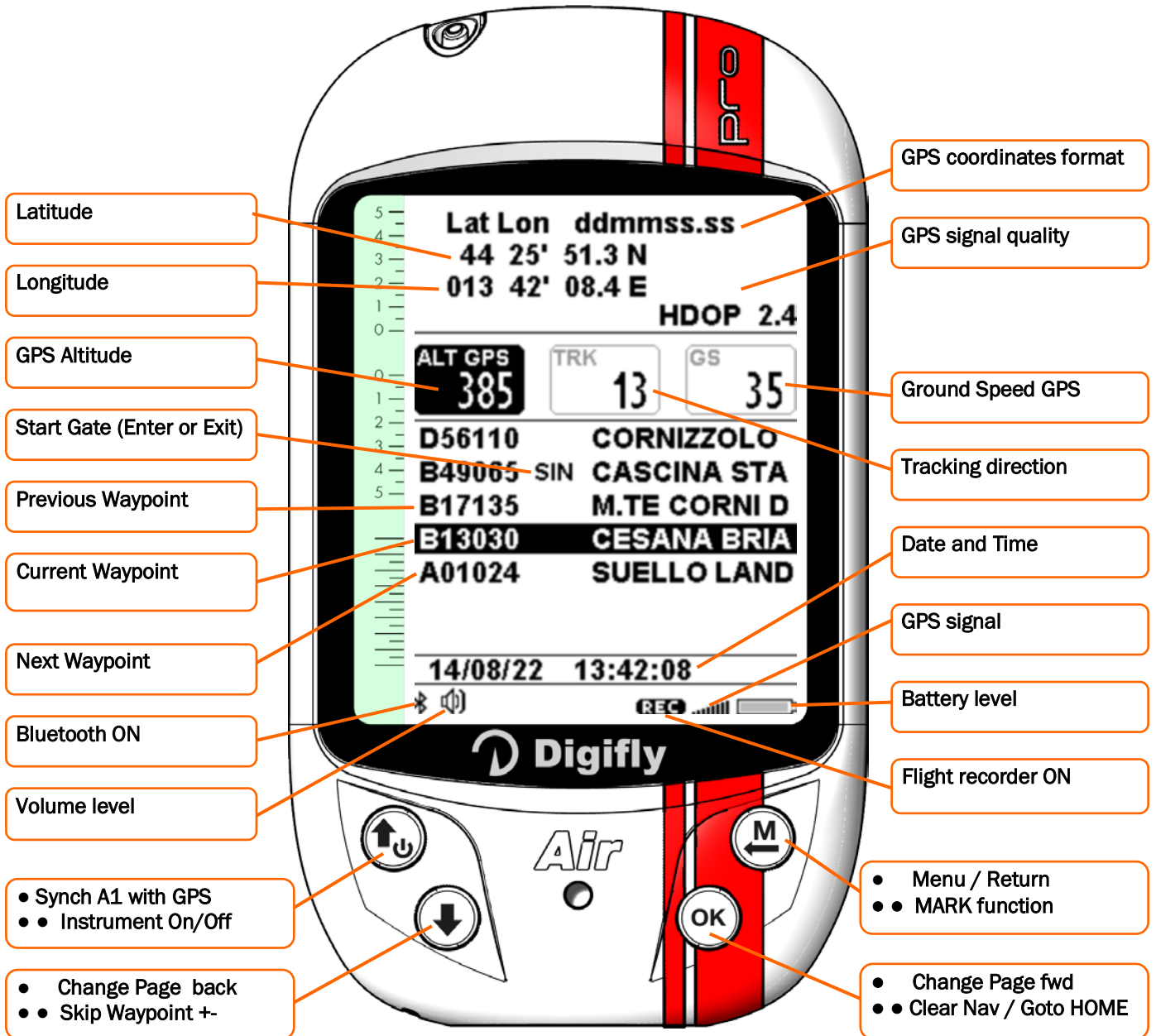

● = Normal key pressure ●● = Long key pressure (2 seconds)

3.9.1 GPS STATUS INFORMATION

- The GPS icon signal has different meanings:
 - Static GPS icon = Correct GPS FIX (GPS position available) 
 - Blinking GPS icon = poor GPS signal (valid GPS position NOT yet AVAILABLE)

3.9.2 LATITUDE & LONGITUDE COORDINATES

- The latitude and longitude coordinates are shown on top, referenced to map datum WGS84.

3.9.3 LATITUDE & LONGITUDE COORDINATES OPTIONS

- There are 4 different coordinate formats available, to choose from:

DMS = degrees, minutes and seconds (dd° mm' ss.s) - default

DMM = degrees and minutes (dd° mm.mmm')

UTM = Universal Transverse Mercator (utm x, y, zone).

DDD = decimal degrees (dd.ddddd)

To set the preferred DMM, DMS, UTM or DDD formats, go to: MENU \ **MAIN SETUP** \ n. 8 **CORD**.

3.9.4 GPS SIGNAL QUALITY

- Type of Fix Information: GPS = normal fix, SBAS = fix with SBAS backing
- Number of Satellites Used for Fix
- The HDOP value represents the weakening of GPS signal; lower values mean good precision.

3.9.5 GPS ALTITUDE

- GPS altitude ("ALT GPS") represents the height over sea level given by the GPS system.

3.9.6 GPS DIRECTION (TRK)





- GPS direction ("TRK") represents the aircraft's direction relative to the ground.

3.9.7 GPS GROUND SPEED

- The GPS ground speed is the aircraft's speed relative to the ground ("Gs").

3.9.8 REAL TIME NAVIGATION MANAGER / SKIP WAYPOINT

- The central part of the GPS INFO page shows the navigation progress of an active route in real time; you see the waypoint list of the active route, where the current waypoint is highlighted in "reverse" (white over black).
- In case navigation to a single waypoint is active, the central part of GPS **INFO** page will show only the name of the current waypoint.
- The "**Skip Waypoint**" function allows you to choose to navigate to a different waypoint (previous or next):

Only from the **GPS INFO** page, with an active route, **LONG PRESS** the  button; the list will appear, press the  button to jump to the previous Waypoint or press  to jump to the next Waypoint. Press  to cancel.

- The Digifly AIR also has a shortcut for the "Skip Waypoint" function, from any of the navigation pages. In order to activate it, the "**Skip Waypoint Shortcut**" parameter (**ADVANCED SETUP** \ n. 22 **SKPW**) needs to be activated.

Keep in mind that this will change the functions of some buttons:



With the parameter set to **OFF** = Shortcut disabled (default), **LONG PRESSING** the "ARROW DOWN" button changes the volume level and **LONG PRESS** of the "OK" button sets the A2 altimeter to zero.

However, with the parameter set to **ON** = Shortcut enabled and, when a route is activated both for competition

or XC, **LONG PRESSING** the "ARROW DOWN" and "OK" buttons, will respectively work as skipping a waypoint back and forward buttons, without having to go to the Info GPS page first.

3.9.9 CREATING A NEW WAYPOINT USING THE CURRENT POSITION (MARK)



- "MARK" function: when the GPS acquires a valid position, it is possible to save it in the instrument's memory.

From the **GPS INFO** page **LONG PRESS** the  key; the message "Save Mark ?" is shown, press the  key to confirm or the  key to cancel. The current position will be saved as a new Waypoint in the **User Waypoint** list ("WPT USER") with the format nnMaaa (aaa= altitude GPS in tens of meters)



3.9.10 NAVIGATION TO "HOME" WAYPOINT (GOTO HOME)

- Available only on the **GPS INFO** page, it ensures that the instrument guides us back to the point where we activated this function from.

It is particularly useful, for example, when flying at a new site without any waypoints and want to be guided to the official landing zone (LZ). In this case, it is necessary to go to the LZ and activate this function there.



- How to activate the "GOTO HOME" function: from the **GPS INFO** page, with valid GPS position, **LONG PRESS** the  key, the message "Activate Home Wpt ?" is shown, press the  key to confirm or  to cancel.

Note: if navigation has been previously activated, it is necessary to deactivate it first: from the **GPS INFO** page

LONG PRESS the  key, the message " Clear Nav ?" is shown, press the  key to confirm or  to cancel.

The "GOTO HOME" function creates a landing waypoint in the User Waypoint list ("WPT USER") with the current position data "HOMaaa" (aaa = GPS altitude in tens of meters) and with the icon "A" (Airfield), at the same time, it activates the navigation to it (GOTO).

3.9.11 DEACTIVATING THE CURRENT NAVIGATION (CLEAR NAV)

- **CLEAR NAV** function: to disable the active navigation, **LONG PRESS** the  button, the "Clear Nav ?" message will appear, confirm with the  button or press  to cancel.

3.9.12 DATE & TIME

- Date and current time are automatically updated with GPS data when you start the instrument and will continue updating.
- To set time zone you are in, go to: **MAIN SETUP \ n. 7 UTCO.**

4 MAIN FUNCTIONS

4.1 ALTIMETERS

- The Digifly AIR features 9 different altimeters: ALT 1, ALT 2, ALT 3, ALT QNE, ALT FL, ALT GPS, ALT H1, ALT HA, and ALT AGL.
- **ALT 1 (A1)** : Barometric altimeter
- **ALT 2 (A2)** : A2 Altimeter
- **ALT 3 (A3)** : Gain during the current thermal
- **ALT QNE (QE)** : QNE Standard Pressure Altitude. Barometric height recorded in your tracklog.
- **ALT FL (FL)** : Flight Level Height Barometric Altimeter referring to the standard pressure in flight levels (hundreds of feet).
- **ALT GPS (AG)** : GPS Altimeter
- **ALT H1 (H1)** : Estimated height over the cylinder of the current WP
- **ALT HA (HA)** : Estimated height relative to goal cylinder, line, etc.
- **ALT AGL (HG)** : Height above ground level with map (see 4.1.1 and 6.17.1)

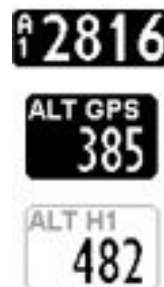

4.1.1 AGL ALTIMETER

- The **AGL** altimeter, shows the height above ground, (**AGL = Above Ground Level**). To activate the **AGL** altimeter, you must have a microSD card with the *.dgm map files of the area you will be flying -created using AirTools- in your Digifly and that the “Elevation Mode” parameter (**ADVANCED SETUP \ n. 16 ELVM**), is set to either 1, 2 or 3. A detailed description on how to create a map and how to set the map parameters see section 6.17.1.

4.1.2 ALTIMETERS' SETTINGS

- **Graphic Altimeter** : digital value of A1 altimeter is integrated with the graphic scrolling altimeter. With a friendly scale and numeric indications every 500 mt/ft embedded into an angular graphic view making the numbers more readable.

There is also a simple graduated scale for meters in the hundreds.



4.1.3 ALTIMETERS' SETTINGS

- Go to the “**ALTIMETERS**” menu and select which altimeter you want to adjust (A1 or A2).
Important: while the recorder is activated is not possible to adjust the A1 Altimeter.
- Synchronizing the A1 Altimeter with the altitude provided by GPS data:
If the “A1-GPS sync.” is enabled, (**ADVANCED SETUP \ n. 11 A1SY** default= ON), you are not yet moving (in flight) and have not manually set the A1 altimeter, this altimeter will automatically synchronize with the GPS data.

To manually synchronize the A1 altimeter with the altitude data from the GPS, press the  button. This may only be done when the instrument has acquired GPS coverage, if you are not moving and if the A1SY parameter is set to ON. Once the flight recorder has started, this synchronization is no longer possible.

- The **A2** Altimeter is used for general purposes. To reset it **LONG PRESS** the  key. **Note** that with the “Skip Waypoint” shortcut parameter activated **ADVANCED SETUP \ n. 22 SKPW=ON**) the “OK” button will have a different function: it will take you to the next waypoint on your route and will no longer zero the A2 altimeter.
- With the parameter **ADVANCED SETUP \ n. 12 A2AU=ON**, the AIR will automatically set the Altimeter 2 to zero, right after launch.
- The **A3** Altimeter is automatically reset when you start thermalling.
- The altimeters can be shown in meters (mt) or feet (ft), to set up, go to: **MAIN SETUP \ n. 9 U-AL**.

4.1.4 MAXIMUM ALTITUDE ALARM

- This parameter (**ADVANCED SETUP \ n. 10 A1AL**) will notify you when you reach the set altitude; the alarm will be reset once you go back down below the set threshold by 10m (33ft).
- It ranges from 0 to 9,000ft (approx.. 29,500ft) and default setting is 0. Set to 0, the alarm is off.

4.2 VARIOMETERS

4.2.1 11-SENSORS VARIOMETER WITH SELF - ADAPTIVE SENSITIVITY

- It's a revolutionary digital system designed by Digifly, based on a sophisticated data acquisition system updated 100 times each second that merges 11 sensors: the atmospheric pressure sensor data with the Pitot tube sensor and the 9 sensors of the synthetic inertial data platform (3 synthetic accelerometers, 3 synthetic magnetometers and 3 synthetic gyroscopes).
- It is also equipped with **self-adaptive sensitivity** that auto-modulates the instruments sensitivity according to the air's conditions: it increases it in weak conditions and decreases in strong conditions or turbulence.

This allows to have a vario with high sensitivity and instantaneous response, that is yet fluid and immune to the turbulence while very helpful in weak conditions, thanks to its pre-thermal function. Furthermore, in contrast to varios, based on a pressure sensor only, the Digifly is not affected by false readings due to acceleration.

Important Notes: The mathematical method that manages the variometer has been optimized to obtain an excellent response during flights; for this reason, we suggest you try or compare it flying and not on the ground.

- Even though the system is totally automated it is possible to manually force the values of some filters: Parameter **VARIOMETER SETUP \ n. 15 RVAR**, ranges from 1 (minimum reactivity) to 20 (maximum reactivity); default 10.

4.2.2 DIGITAL VARIO

- Shows instant climbing or descending values in a range of +/- 25 m/s in digital format +/- 5,000 fpm.

4.2.3 ANALOGICAL VARIO

- Indicates the instant vario values; it is displayed by the analogical bar indicator on the left of the screen that shows the sink or climb rate within a +/- 5 m/s range, +/- 500 fpm range.

4.2.4 INTEGRATED (AVERAGE) VARIO

- The right-hand bar shows the integrated vario values; the average of the instant vario during X amount of time (this bar can be changed to the value of the net vario, see section 4.2.6).
- It can be used to monitor the progression of your climb to see if it is getting better or worse. For example, if the integrated vario value is higher than the instant vario, it means that the climb was previously stronger; it can be used, therefore, to better core the thermal.
- The averaging time (integration time) can be set with **VARIOMETER SETUP \ n. 16 INTE**, ranging from 5 to 60 seconds.

4.2.5 NET VARIO (WITH OPTIONAL PITOT TUBE)

- The bar on the right hand, analogically indicates the climb/descent rate values of the air mass around you in a +/- 5m/s (approx. 1,000fpm) range. It can also be set to display the average vario values instead (see 4.2.6).
- When the netto vario is being displayed, the icon "NET" will show on the right-hand bar.
- **N.B.** In order to use this function, you must have a Digifly AIR with Pitot Tube option and that the tube is installed on the instrument; also, you need to have the Polar coefficients to be programmed in your instrument (for example, you have Polar 1: **GLIDE COMPUTER SETUP \ n. 21 ... 28**) and set the Polar parameter to use the values stored for Polar 1 (for example, Polar 1: **GLIDE COMPUTER SETUP \ n. 20 POLA=P1**).



4.2.6 INTEGRATED VARIO / NET VARIO AUTOMATIC SWITCH

- You can change the vario's indicators layout using **VARIOMETER SETUP \ n. 17 DSEL** :
 - 0 = (default), the right-side analog bar shows the average vario and the digital indicator shows the instant vario.
 - 1 = right-side analog bar and digital indicator always show average vario values.
 - 2 = right-side analog bar and digital indicator always show net vario values.
 - 3 = right-side analog bar and digital indicator change depending on effective flight conditions: when you are gliding, the right-side analog bar and the digital indicator both show net values and, when you are thermalling, the right-side analog bar shows the average vario values and the digital indicator shows the instant vario values.
 - 4 = right-side analog bar and digital indicator change depending on effective flight conditions: when you are gliding the right-side analog bar and the digital indicator both show net values, when you are thermalling, the right-side analog bar and the digital indicator both show average vario values.
- When the net vario value is shown, the “**NET**” icon will appear vertically on the right bar.
- Thermalling mode / Gliding mode:** it switches to “Thermalling” mode when it feels a new thermal for more than x seconds (**GLIDE COMPUTER SETUP \ n. 4 THET**) default 2 seconds and you make a turn to fly into it; it switches to “Gliding” mode when you fly “straight” for more than x seconds defined in **GLIDE COMPUTER SETUP \ n. 3 CRUT**; default =15 seconds.



4.2.7 McCREADY (WITH OPTIONAL PITOT TUBE)

- The McCready value is the average lift value of the last “nn” minutes in thermal
- To adjust the average lift time: **GLIDE COMPUTER SETUP \ n. 14 MCRA**. (default: 10min)
- N.B.** In order to be able to use this function, you must have the Digifly AIR with Pitot Tube and have the tube installed in your instrument; also you need to have the Polar data programmed (for example, you have Polar 1: **GLIDE COMPUTER SETUP \ n. 21 ... 28**) and set the Polar parameter to use the values stored for Polar 1 (for example, Polar 1: **GLIDE COMPUTER SETUP \ n. 20 POLA=P1**).

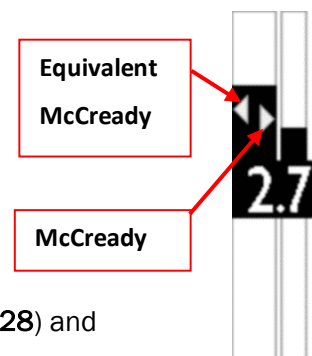

4.2.8 EQUIVALENT McCREADY (WITH OPTIONAL PITOT TUBE)

- This value indicates the Equivalent McCready value: this is the McCready value, considering the current airspeed as the optimal speed.
- The equivalent McCready, based on the glider's polar, the sink rate and the current airspeed (IAS), indicates in real time at which true McCready value we are flying compared to the optimal speed. When this value matches the one estimated in the thermal, this means that the current airspeed (IAS) matches the optimal speed (see “Speed to Fly” section 4.3.1).
- To set the reaction time of the Equivalent McCready indicator go to: **GLIDE COMPUTER SETUP \ n. 15 MCRE**.
- N.B.** In order to be able to use this function, you must have the Digifly AIR with Pitot Tube and have the tube installed in your instrument; also you need to have the Polar data programmed (for example, you have Polar 1: **GLIDE COMPUTER SETUP \ n. 21 ... 28**) and set the Polar parameter to use the values stored for Polar 1 (for example, Polar 1: **GLIDE COMPUTER SETUP \ n. 20 POLA=P1**).

4.2.9 TOTAL ENERGY COMPENSATION (WITH OPTIONAL PITOT TUBE)

- To use this function, it is necessary to have the optional Pitot tube installed.

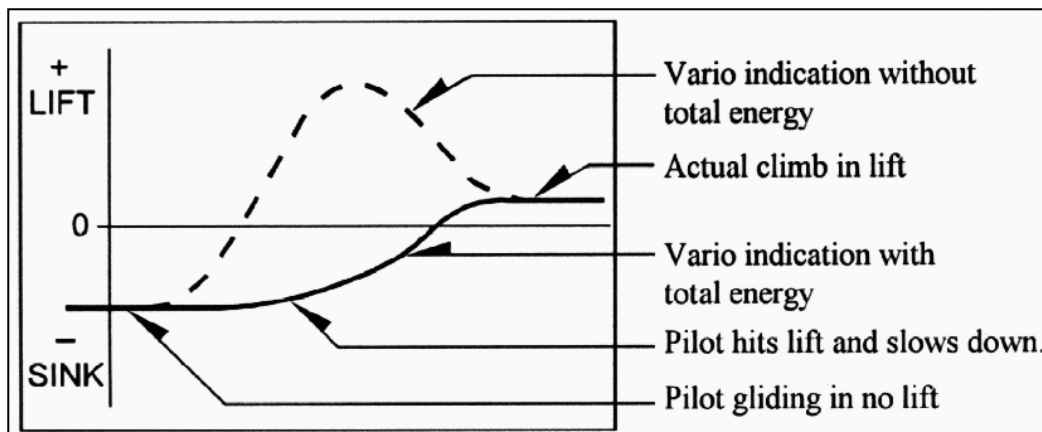

- Generally, a variometer works as follows: it feels the atmospheric pressure change rate considering it as an altitude change, but, if during the flight the pilot slows the glider (and even more so if done quickly), there is a real change of pressure, so a vario 'without compensation', records it as a climb, but this variation is caused by a change of speed (kinetic energy) and not due to a true thermal.
- With the Total Energy Compensation function, the part of the climb due to the change in velocity is ignored, allowing you to identify the "real" thermals.
- To properly set the TOTAL ENERGY compensation values, you need the following parameters:
 - "Total Energy Compensation Mode" (**ADVANCED SETUP \ n. 6 TECM**) : OFF = T.E.C. off (default), ON = T.E.C. is calculated during glide only, FUL= T.E.C. is calculated both during glide and in thermals.
 - "Total Energy Compensation" (**ADVANCED SETUP \ n. 7 TEC**), to set this percentage correctly, you should fly in calm air conditions and slow down as if you were entering a thermal. If the vario shows a change in lift, you have to increase the total energy compensation value, until the change in velocity is no longer recorded as lift; a typical value for hang gliders is 65.
 - "Total Energy Compensation Average" (**ADVANCED SETUP \ n. 8 TECA**): it is the average applied to the total energy component, the range goes from 1 (fast) to 99 (slow); default 80.

4.2.10 ACOUSTIC VARIO

- The acoustic vario represents the instantaneous values of the vario with a modulated acoustic tone.
- **LONG PRESSING** the  key while on any page (except Info GPS) changes the vario volume (3 settings): “HIGH”, “OFF” & “LOW”.

The chosen volume is shown by the ‘loudspeaker’ icon on the bottom left side of the display.

Please note that if the SKPW (**ADVANCED SETUP \ n. 22 SKPW**) parameter is ON, the function of **LONG PRESSING** the “arrow down” button, while flying with an active route will skip to the next waypoint and not adjust the volume; therefore, make sure you set the volume level before activating the route.

Remember that when you turn your Digifly AIR on, it checks the volume of the acoustic vario and, if it happens to be turned off, it will immediately turn it up to HIGH.

- To set the sound’s threshold level to indicate lift, go to: **VARIOMETER SETUP \ n. 1 V.UP**; for the sink’s threshold, go to: **VARIOMETER SETUP \ n. 3 V.DN**.

- **New Acoustic Vario and New Pre-Configured Sound Profiles**

The new acoustic vario has been rendered more flexible and more powerful, capable of emulating any type of sound; this function is very important because it allows a pilot coming from any other instrument brand to set up the acoustic vario so that it will have the same sound profile to which he/she was used to. For example, selecting PROF=DG3, acoustic vario will sound like a Bräuniger / Flytec vario.

Acoustic Vario Parameters:

- **VARIOMETER SETUP \ n. 4 DYNH** “Enable Dynamic Frequency”: OFF=disabled, ON=enabled (default)
Note: It will apply to every sound profile.
- **VARIOMETER SETUP \ n. 5 DUMP** “Dynamic Frequency Average” : from 1 to 15= (default 15) 1=no average, 15=max. average. Remember: this parameter only works if the DYNH parameters is ON and is set up according to your own personal taste, every time a different sound profile is selected:
It is already a compromise between response rate and fluidity: very low values will produce quite a reactive sound, but it will make the “piano” effect with abrupt note changes and with very high values, the sound will be a lot more fluid, but it may lag on the response rate side
Note: It applies to every sound profile.
- **VARIOMETER SETUP \ n. 6 PTMD** “Pre-Thermal Mode”: 0=pre-thermal sound during glide only (default), 1= pre-thermal sound during both thermal and glide.
Note: In previous firmware versions, this function could be enabled using the Variometer Setup parameter **AUTV** set to FUL, in this version, the AUTV parameter is limited to ON/OFF (setting the autovario to on or off).
Note: It applies to all sound profiles.
- **VARIOMETER SETUP \ n. 7 PROF** : “Acoustic Vario Profile”: SFT, STD, FAS, US1, US2, MAN, DG1, DG2 (default), DG3, DG4
The following preset sound profiles were added to this firmware version: DG1, DG2, DG3, DG4

- **DG1:** this sound profile corresponds to the previous default sound profile on firmware 506a.

Note: The suggested initial settings for this profile are:

- DYNH=OFF
- DUMP=15
- PTMD=0
- PROF=DG1
- RVAR=16

- **DG2:** (default) new Digifly official sound profile.

Note: The suggested initial settings for this profile are:

- DYNH=ON
- DUMP=15
- PTMD=0
- PROF=DG2
- RVAR=5

- **DG3:** sound profile equivalent to the Bräuniger / Flytec standard sound.

Note: The suggested initial settings for this profile are:

- DYNH=ON
- DUMP=15
- PTMD=0
- PROF=DG3
- RVAR=5

- **DG4:** Equivalent Bräuniger / Flytec slightly more “aggressive” sound profile.

Note: The suggested initial settings for this profile are:

- DYNH=ON
- DUMP=15
- PTMD=0
- PROF=DG4
- RVAR=5

If the **VARIOMETER SETUP \ n. 7 PROF=MAN** the following parameters will be enabled; otherwise, they are irrelevant:

- **VARIOMETER SETUP \ n. 8 UPHZ:** basic climb frequency: 400.....1400 Hz (500 Hz default)
- **VARIOMETER SETUP \ n. 9 MODH:** climb modulation frequency: 1....25 Hz (14 Hz default) Hz/10cm
- **VARIOMETER SETUP \ n. 10 CURH:** climb curve selection frequency: 1...4 (2 default)
- **VARIOMETER SETUP \ n. 11 TONB:** base ton time: 100....1000 mS (400 mS default)
- **VARIOMETER SETUP \ n. 12 TOFB:** base toff time: 0....1000 mS (300 mS default) (0=continuous sound)
- **VARIOMETER SETUP \ n. 13 PITC:** climb cadence curve selection: 0....10 (2 default)
- **VARIOMETER SETUP \ n. 14 DWHZ:** basic sink frequency: 350.....1000 Hz (400 Hz default)



Note: these default values (from UPHZ to DWHZ) are identical to those preset for the DG2 sound profile.

- **Auto-silence (VARIOMETER SETUP \ n. 19 AUTV):** “ON” by default, it activates the acoustic vario only after takeoff and stops it 60 seconds after landing.

4.2.11 ACOUSTIC VARIO PRE-THERMAL TONE

- If activated, an acoustic signal with a tone and modulation significantly different of the acoustic vario, indicates that we are near a thermal (the instantaneous sink rate is better of the glider’s minimum sink rate, therefore indicating an area of slightly climbing air). To set the pre-thermal sound’s threshold go to: **VARIOMETER SETUP \ n. 2 V.PT**; value from 0,00 to 1,50 m/s and the suggested value is 0,50 m/s.

4.2.12 VARIO SIMULATOR

- For a perfect tuning of the acoustic vario, without flying, it is possible to set the ‘Vario Simulator’ mode, setting the **VARIOMETER SETUP \ n. 18 SIMV** parameter to “ON” and **VARIOMETER SETUP \ n. 19 AUTV** to “OFF”. Then exit from menu and use the arrow keys   to set the preferred vario sound. To deactivate the simulator set **SIMV** to “OFF” and **AUTV** back to “ON”.

Note: for safety reasons the simulator is automatically deactivated when the instrument power on.

4.3 AIRSPEED (WITH OPTIONAL PITOT TUBE)

- This sensor measures the glider's airspeed.
- This function is available only with the Pitot tube sensor module (optional). The tube will have to be inserted in the specific housing hole located on the instrument's top and the parameter **ADVANCED SETUP \ n. 1 PITO** has to be set on the desired value: **IAS** (Indicated Airspeed) or **TAS** (True Airspeed).
- It is possible to set the speed's unit of measure to km/h or mph using the parameter **MAIN SETUP \ n. 10 U-SP**
- The minimum speed indication is 18 km/h, 11 mph.



4.3.1 SPEED TO FLY (WITH OPTIONAL PITOT TUBE)

- Speed to Fly (STF) is the best anemometric speed to obtain the best glide ratio; this value depends on performance of your glider as well as vertical and horizontal airflow. In calm air, the optimum flying speed is the same as the best glide speed (point B).

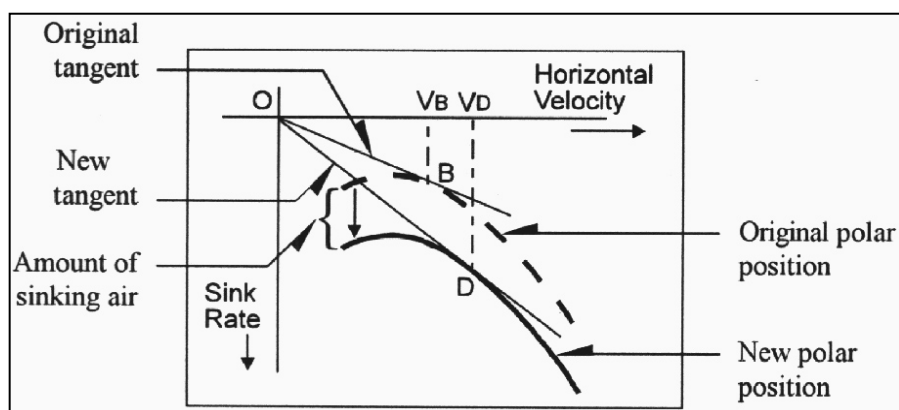

- The diagram shows different values of speed to fly related to different flight conditions
- The X-axis shows horizontal speed; the Y-axis shows sink rate. With headwind or sink conditions, the best glide speed increases. In order to find the optimum speed to fly value in sink conditions, the sink rate of the air is added to the polar of your glider, drawing a new polar and a new tangent line from the initial point of axes. The new tangent (point D) meets the polar at the point giving a higher optimum flying speed VD.

- To fly at the correct "STF", adjust your flying speed "IAS" to match the STF indicator (triangle symbol) with the value on the optimal anemometric speed.
- **N.B.** In order to be able to use this function, you must have the Digifly AIR with Pitot Tube and have the tube installed in your instrument; also you need to have the Polar data programmed (for example, you have Polar 1: **GLIDE COMPUTER SETUP \ n. 21 ... 28**) and set the Polar parameter to use the values stored for Polar 1 (for example, Polar 1: **GLIDE COMPUTER SETUP \ n. 20 POLA=P1**).

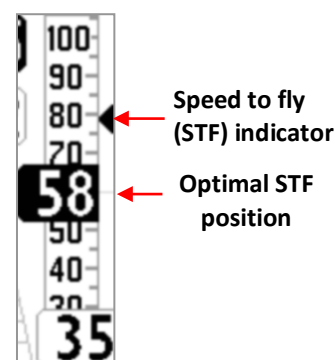

4.3.2 ACOUSTIC McCREADY (WITH OPTIONAL PITOT TUBE)

- **Conditions for setting up and turning the McCready sound on:**
 - McCready sound enabled: **GLIDE COMPUTER SETUP \ n. 16 MCRS=1** or 2
 - Pitot enabled: **ADVANCED SETUP \ n. 1 PITO=IAS** or TAS
 - Polar enabled: **GLIDE COMPUTER SETUP \ n. 20 POLA=P-1** or P-2 or P-3
 - The instrument must NOT be on the “Info GPS” page (while on this page, long pressing the “M” button will create a “mark gps” point)
 - The instrument must NOT be on the “Map” page (while on this page, long pressing the “M” button will access map options)
 - The instrument must be on a page that displays the “Analog Vario Bargraph”
 - Long press the “M” button (the Digifly will beep twice and a small arrow will appear on the combined vario instrument’s secondary bar, to confirm that the acoustic McCready is now on)
- N.B.** if MCRS=2=manual setpoint : the McCready sound setpoint is set with the value of the parameter **GLIDE COMPUTER SETUP \ n. 13 MMCR** “Manual McCready”
- N.B.** if MCRS=1=dynamic setpoint : in this case these additional conditions are necessary : the graphic Equivalent McCready indicator ranges from 0,0m/s and up, instant vario in sink and “Glide” flight mode ; the McCready sound setpoint is set with the current value of the Equivalent McCready.

Note: Once turned on and while on glide, the acoustic McCready will emit a sound to let you know that you are in sink, regardless the page you are on.

You will not mistake the acoustic McCready and the Pre-Thermal sounds because when the acoustic McCready is turned on, the Pre-Thermal and Sink Alarms are disabled.

- **Conditions to Turn the Acoustic McCready Off:**
 - The instrument must NOT be on the “Info GPS” page (while on this page, long pressing the “M” button will create a “mark gps” point)
 - The instrument must NOT be on the “Map” page (while on this page, long pressing the “M” button will access map options)
 - Long press the “M” button (the Digifly will beep once, to confirm that the acoustic McCready is now off)

Note: the acoustic McCready will also be automatically disabled every time the instrument is turned on and every time you access the MENU page.

- **Example:**
 - Required setting: **GLIDE COMPUTER SETUP \ n. 16 MCRS=1**, **ADVANCED SETUP \ n. 1 PITO=IAS** (or TAS), **GLIDE COMPUTER SETUP \ n. 20 POLA = P-1** (or P2 or P3).
 - Instrument on pg 8 XC Glide (example); the Standard pg 8 has the analog graphic vario with the Equivalent McCready).
 - Flying on “Glide” mode (which means that you are on a somewhat straight course for at least 15 seconds).
 - Vario in sink (for example flying at -0.2m/s, approx. -40fpm).
 - Adjust the gliding speed until the graphic Equivalent McCready indicator reaches the desired value (for example, +2.5m/s, approx. 500fpm).
 - You long press the “M” button to turn the acoustic McCready on (you will hear a confirmation double beep) and saves the current Equivalent McCready as the target McCready value to maintain during glide, the target value is displayed with a new small arrow on the combined vario instrument’s secondary bar .

- The target McCready range is: 0m/s ... +10m/s.
- From this point on, when gliding and in sink, you will hear a pulsing sound with a frequency that is proportional to the deviation of the current Equivalent McCready regarding the target Equivalent McCready. The sound will be emitted only when the deviation is higher than +/-0.3m/s, approx. +/-60fpm (quiet zone or dead band).
- To turn the acoustic McCready off, simply long press the “M” button again (a single beep will confirm your input)

4.3.3 SPEED DIFFERENCE (WITH OPTIONAL PITOT TUBE)

- The “Speed Difference Enable” (**ADVANCED SETUP \ n. 3 SDIF**) parameter = ON displays the head wind component (=Ground Speed – Anemometric Speed), on the digital indicator on the bottom of the combined speed instrument, instead of the Ground Speed value. A negative value indicates headwind

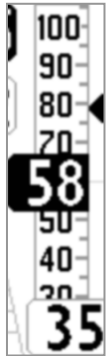

4.3.4 STALL ALARM (WITH OPTIONAL PITOT TUBE)

- The Stall Alarm is activated setting the parameter **ADVANCED SETUP \ n. 2 STAL** with the desired speed. It ranges from 0 to 150km/h (default setting: 0km/h). An alarm will sound as soon as you reach a speed below the set speed. The default setting of 0km/h keeps the alarm off.

4.3.5 AIRSPEED CALIBRATION (WITH OPTIONAL PITOT TUBE)

- **Pitot tube sensor calibration**

- turn the instrument on, in a place where you don't have any wind (preferably indoors).
- set the parameter **ADVANCED SETUP \ n. 5 KIAS = 100 %**
- write down the offset value of the Pitot sensor (is the 4-digit number visible on PAGE 10 RELAX placed above the variometer indicator).
- use this value to set the **ADVANCED SETUP \ n. 4 OFSP** parameter.

Pitot offset value

This parameter can only be modified directly using the menu on the AIR instrument and not using the AirTools software.

Warning: If used incorrectly, this feature will render your airspeed indicator less accurate.

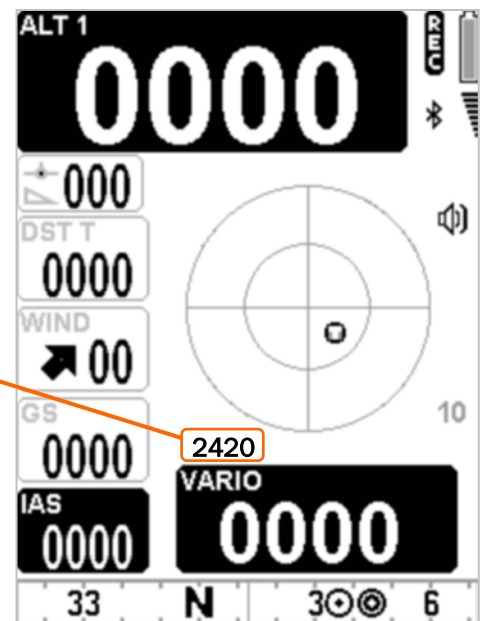

4.4 POLAR (WITH OPTIONAL PITOT TUBE)

- A polar curve (see figure below) is the graph of your glider's sink rate over its speed range.
- **S** is the glider's stall speed (on the left) and **T** is the glider's max speed (on the right).
- On the graph, you can also see three pairs of relative speed readings and sink rates. The graph shows at point **A**, the lowest sink rate achieved at the top of the curve; therefore,

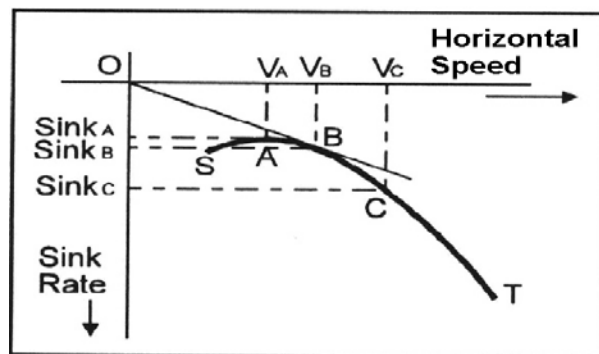

Sink A is the minimum sink rate and **VA** is the speed at which this is achieved.

- The glide ratio is the ratio between the glider's horizontal speed and its sink rate. To find the best glide rate on the graph, it is necessary to draw a straight line from the origin of the graph (point **O**) tangent to the curve.
- The intersection of the tangent with the curve (point **B**) shows the speed to fly (**VB**) to achieve the best glide, where you are in **B** sink; so, your best glide ratio is **VB / Sink B**.
- **How to edit the polar curve data of your own glider :**
- In order to be able to use this function, you must have the Digifly AIR with Pitot Tube and have the tube installed in your instrument.
- On the instrument, there are three preloaded polar :
 Polar 1 : competition paraglider : L/D max eff 11.0 @ 40 kmh
 Polar 2 : intermediate hang glider : L/D max eff 11.6 @ 43 kmh
 Polar 3 : topless competition hang glider : L/D max eff 15.0 @ 50 kmh.
- We suggest that you insert your own polar curve data which best reflects the actual performance of your glider; for each single polar to be used, enter these data directly on the instrument:
 3 speeds with corresponding sink rates, speed type (IAS / GS) and total takeoff weight.
 Polar 1 : parameters to edit : **GLIDE COMPUTER SETUP \ n. 21 ... 28**
 Polar 2 : parameters to edit : **GLIDE COMPUTER SETUP \ n. 29 ... 36)**
 Polar 3 : parameters to edit : **GLIDE COMPUTER SETUP \ n. 37 ... 44)**
- To choose which polar to use, go to (**GLIDE COMPUTER SETUP \ n. 20 POLA**), if this parameter is set to "OFF", all the information relating to **McCready**, **McCready Equivalent**, and **Net Vario** are not displayed on the instrument.
- To enter your ballast weight edit the parameter (**GLIDE COMPUTER SETUP \ n. 19 BLST**).

- **How to display the current polar curve data :**

- If one of the polar is active, it will be continuously recalculated in real time and displayed on the top of Standard

PAGE 11 "**GLIDE COMPUTER**", its layout is:

- Best efficiency value (L/D max eff)
- Speed in km/h at max. efficiency (speed max eff)
- Descending rate at max. efficiency (m/s max eff)

15.0 L/D max eff
50 speed max eff
-0.93 m/s max eff

4.5 BAROMETER

- The barometer displays the atmospheric pressure in millibar.
- It is possible to adjust its calibration with the **ADVANCED SETUP \ n. 9 KBAR** parameter.
- This parameter can only be modified directly using the menu on the AIR instrument and not using the AirTools software.
- **Important:** when the recorder is activated or the instrument detects movements, it is not possible to change this parameter.
- **Warning :** incorrect adjustment of this parameter will make the barometric altimeters less accurate

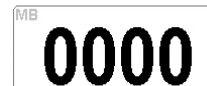

4.6 TIME

- The current time (**RTC** or **RT**) is automatically synchronized with the GPS data when the instrument is turned on and will continue to synchronize automatically throughout your flight.
- To set the time zone you are in, go to: **MAIN SETUP \ n. 7 UTCO**.



4.7 CHRONOGRAPH

- The Chronograph **CHRONO (CH)** is automatically reset to zero when the instrument is turned ON. It will remain at 00:00 until the flight begins and will stop when you land, but it will not immediately go back to 00:00. So, if you were to take off again, without turning your instrument OFF and back ON, the chronometer would continue from where it stopped, without resetting.

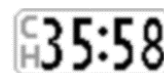

4.8 PILOT'S NAME & GLIDER'S INFO

- To set the pilot name, glider type and glider ID, go to: **MAIN SETUP \ n. 12 PILO**, **MAIN SETUP \ n. 13 GTYP** and **MAIN SETUP \ n. 14 GID**.

5 ADVANCED FUNCTIONS

5.1 SYNTHETIC INERTIAL PLATFORM

- The synthetic inertial platform produces data regarding space location.
Made by a data acquisition system that with a complex processing algorithm calculates 3 synthetic accelerometers , 3 synthetic magnetometers and 3 synthetic gyroscope.

6 GPS FUNCTIONS

6.1 INTEGRATED GPS MULTI-CONSTELLATION RECEIVER WITH 99 CHANNELS

- Digifly AIR features an extremely sensitive, and state-of-the-art, integrated GPS multi-constellation receiver with 99 channels.

6.2 GPS STATUS INFORMATION

- The GPS status icon has different meanings:
 - Fixed GPS icon = GPS FIX valid (GPS position available) 
 - Blinking GPS icon = insufficient signal (GPS position NOT yet AVAILABLE)

6.3 GPS SIGNAL QUALITY (HDOP)

- The HDOP value represents the weakening of the GPS signal; lower values mean good precision.

6.4 EARTH MODEL USED FOR DISTANCE CALCULATION

- The parameter **GLIDE COMPUTER SETUP \ n. 2 DCAL** (Distance Calculation Model), allows you to choose the earth reference model used for distance calculation. When set to FAI, it will use the FAI Sphere model and, when set to WGS, it will use the WGS84 model (default).

6.5 TOLERANCE USED FOR DISTANCE CALCULATION

- The parameter **GLIDE COMPUTER SETUP \ n. 1 DTOL** (Distance Calculation Tolerance), allows you to select the tolerance range used in distance calculation. It is a percentage, ranging from 0.0 to 0.5% (default 0.0%).

6.6 LATITUDE & LONGITUDE COORDINATES

- The latitude and longitude coordinates are always displayed on the upper part of the INFO GPS page and are referred to the WGS84 map datum.

6.7 LATITUDE & LONGITUDE COORDINATES OPTIONS

- Four different coordinate formats are available:
 - DMS = degrees, minutes & seconds (dd° mm' ss.s) (default)
 - DMM = degrees & minutes (dd° mm.mmm')
 - UTM Universal Transverse Mercator (utm x, y, zone)
 - DDD = decimal degrees (dd.ddddd)To change the coordinate format DMM, DMS, UTM or DDD, use the **MAIN SETUP \ n. 8 CORD** parameter.
- The latitude and longitude coordinates are referred to the WGS84 map datum.

Lat Lon ddmms.ss		
44 25' 51.3 N		
013 42' 08.4 E		
HDOP 2.4		
ALT GPS	TRK	GS
385	13	35
D56110	CORNIZZOLO	
B49065	SIN CASCINA STA	
B17135	M.TE CORNI D	
B13030	CESANA BRIA	
A01024	SUELLO LAND	
14/08/22 13:42:08		
		

6.8 GPS ALTITUDE

- The GPS altitude (“ALT GPS”) is the height above the sea level accordingly to the GPS satellite system.

6.9 GPS GROUND SPEED

- The GPS ground speed is the glider’s speed related to the ground (“Gs”). This value is always displayed - analogically and digitally- on instruments that do not have the Integrated Airspeed Sensor (Pitot Tube).

6.10 GPS DIRECTION (TRK)

- The GPS direction (“TRK”) is the glider’s direction related to the ground.

6.11 GROUND EFFICIENCY (GLIDE RATIO)

- It shows the instant efficiency (glide ratio) related to the ground when the vario drops below - 0.15m/sec. N.B. When the vario is higher than + 0.10m/sec, the last previously stored average ground efficiency (EFFA) is displayed instead of the instant efficiency.

N.B. If the GPS signal is not valid or the vario is between + 0,10m/sec and - 0.15m/sec , the indicator shows: “.-”.

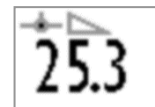

- To set the average time over which the instant efficiency (glide ratio) is calculated, go to: **GLIDE COMPUTER SETUP \ n. 11 EFF**.
- **GLIDE COMPUTER SETUP \ n. 12 EFFA**, to set the time to be used to calculate the average efficiency (glide ratio) to be used for the glide calculation to WP (altitude upon arrival, etc.).
- The average efficiency value is very important because it is the value used by the glide computer by default.

6.12 WIND SPEED AND DIRECTION INDICATION USING GPS

- The wind speed and its direction are automatically calculated using the GPS info Tracking (“TRK”) and the “Ground Speed (“Gs”).
- To determine the wind speed and its direction, you should make a “normal” turn, which has to be neither too tight, nor too wide. It is also important to maintain constant airspeed during the turn.
- For an accurate calculation at least a 360° turn must be completed.
- This function uses the **GLIDE COMPUTER SETUP \ n. 8 WSEN** parameter for the wind calculator sensibility (default 5).
- The (**GLIDE COMPUTER SETUP \ n. 5 WMOD**) parameter selects the wind calculator mode : 1=automatic, 2=manual. With WMOD=2= manual : the wind values are defined by the parameters (**GLIDE COMPUTER SETUP \ n. 6 MWSP = wind speed**) and (**GLIDE COMPUTER SETUP \ n. 7 MWDR = wind direction**)

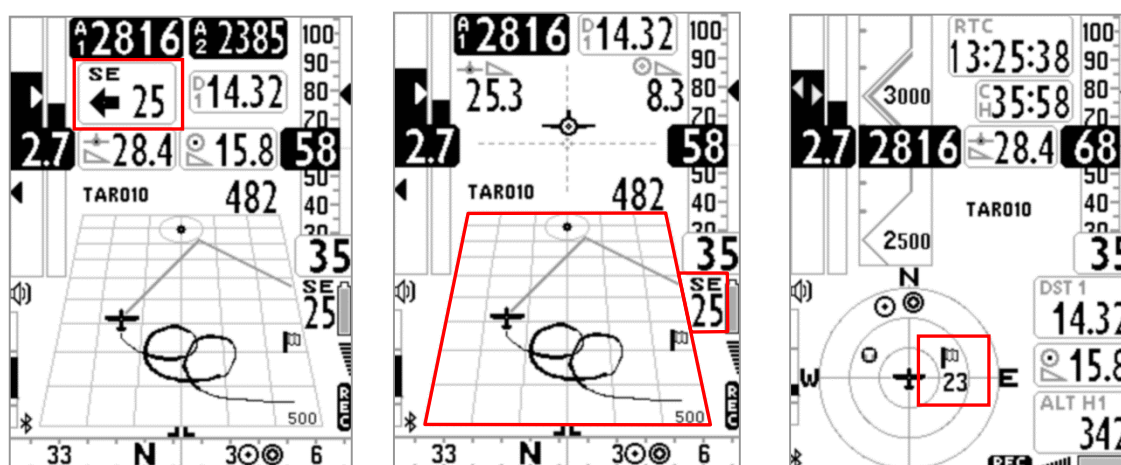

- Wind speed and direction are displayed in different ways on the instrument:
 - On the “Wind Speed” instrument displaying the direction in letters (N, E, SW, etc.); graphically with an arrow and numeric figures (see figure above – left side).
 - On the “Plotter” instrument in two ways: a) Digitally, on the right side of the instrument, showing the direction in letters and the strength in numbers and b) On the grid, it is displayed graphically with a flag

showing the direction it's coming from (see figure above – center).

- On the “Round Compass” instrument it is graphically displayed with a flag showing its direction and strength in numbers, just below the flag (see figure above – right side).

6.13 LAST THERMAL POSITION, DISTANCE & HEIGHT INFORMATION

- The data: direction “BRG T”, distance “DST T” and altitude gain “A3” are displayed when a thermal is detected.
- The thermal’s core position is graphically shown (regarding our current position and in scale) with a “T” inside the Thermal Plotter and in the Thermal Assist instrument as well. Keep in mind that when you use the Circular Compass instrument, the two inner circles also contain the Thermal Assist instrument.
- To recognize a thermal, this function uses the **GLIDE COMPUTER SETUP \ n. 4 THET** parameter where the lift’s minimum duration is set (seconds); the AIR is programmed to differentiate a thermal from gliding in a good line.

6.14 THERMAL ASSIST

- It consists of a graphic instrument that uses two concentric circles and a round icon (letter “T” for thermal) to help you better center the core, taking into account the possible thermal’s drift.
- The center of the circles represents our current position and the “T” is the location of the thermal’s core; therefore, we know where to look for it.
- We can also customize the scale of the “Thermal Assist” instrument in order to have a better idea of how far away we are from “T”; when “T” is in the center of the 2 circles, we are in the core!
- This instrument can be moved on the screen (using AirPages) with a maximum outer diameter of 128 pixels and 40 as a minimum; default 84 pixels.
- This instrument includes the "Thermal Assist Zoom Level" parameter (**ADVANCED SETUP \ n. 21 THEA**) from 1 to 20; default is 5 mt/pixel meaning that the first circle has a 100m / 330ft* radius, and the second circle a 200m / 660ft* radius.
- **Keep in mind** that the “Circular Compass” instrument, movable on the screen (using AirPages), includes the “Thermal Assist” instrument as well, which is located on the first two circles.

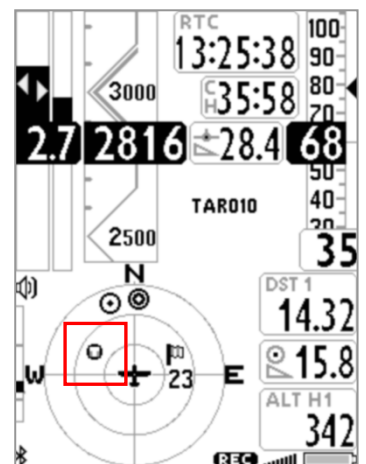
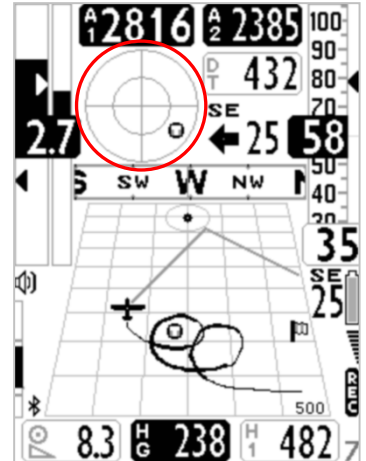

6.15 THERMAL TUTOR

- The thermal tutor is an innovative function capable of helping you center thermals by drawing their track on the “Plotter Instrument” using lines with variable thickness to provide strength information: the thicker the line, the better the climb. You will see a black circle with a “T” showing you the point of maximum climb; this way, finding the core of thermal, becomes very intuitive.
- The track on the plotter is drawn with a zoom factor (auto-zoom); each time that you change flight situation, from thermalling to gliding and vice versa.
- It switches from gliding mode to thermalling mode when it feels a new thermal for more than x seconds (**GLIDE COMPUTER SETUP \ n. 4 THET**); default=2 seconds and if you make a turn to fly into it.

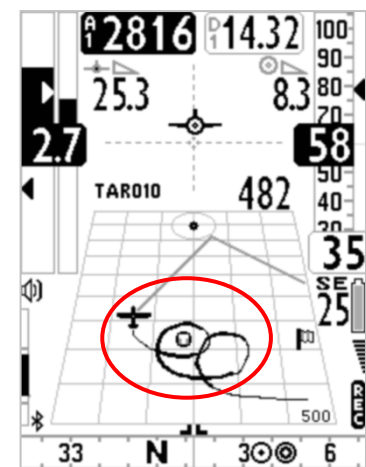

When this happens, the plotter cleans up and zooms to the maximum level of magnification defined by parameter **ADVANCED SETUP \ n. 20 THEZ** “Thermal Tutor zoom level”, assigning a scaled value in mt to every pixel on the screen (default 1mt/pixel).

- It switches from “thermallng” mode to “gliding” mode when you fly “straight” for more than x seconds defined

in **GLIDE COMPUTER SETUP \ n. 3 CRUT**; default =15 seconds. When this happens, the plotter cleans up and the zoom is automatically set on the basis of the calculated distance between the current position and the current waypoint so both can be displayed on the plotter at the same time.

6.16 PLOTTER

- The plotter automatically displays different sets of information depending on the different flight situations.

The plotter is always oriented to the North (North up) if no navigation is active, otherwise it is always oriented to the center of the current waypoint.

- **Information that is always displayed during every flight situation:**

- Aerial position and bearing
- Wind direction flag
- Absolute wind direction (ex. SE)
- Wind strength
- Track of the last 40sec with variable width depending on the variometer's values (i.e. thicker: better lift)
- "T" icon (thermal)
- Scale indicator showing the plotter's width in meters

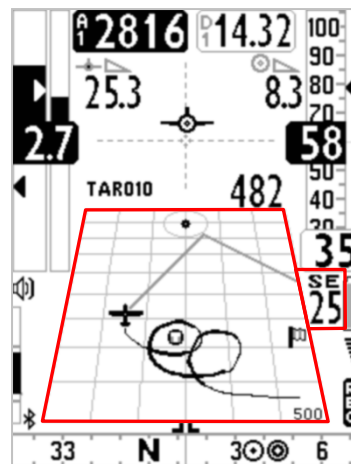

- **In "thermallng" mode:**

- The plotter zooms to the maximum level of enlargement defined by parameter **ADVANCED SETUP \ n. 20 THEZ** "Thermal Tutor zoom level", with a range of 1 to 100 m/pixels; default value is 1 m/pixel, corresponding to 25mt per each plotter's square.

- **Information displayed during glide, without any navigation feature active:**

- The north up symbol "N"
The zoom's value will be fixated at 10 m/pixels, corresponding to 250mt per square.

- **Information displayed in glide when a navigation feature is activated (Route):**

- Sketch of the current waypoint
- Dashed line connecting the airplane (you) to the optimized point of the cylinder of the current waypoint
- Dashed line connecting the optimized point from the current waypoint cylinder to the optimized point of the next waypoint cylinder

The zoom's value is automatically calculated depending on the waypoints' distance

- **Information displayed in glide when the GOTO navigation feature is activated:**

- Waypoint's sketch
- Dashed line connecting the airplane (you) to the center of the waypoint
The zoom's value is automatically calculated depending on the waypoint's distance.

6.17 MAP

- The **Map** instrument enables you to view several graphic information sets (layers) at the same time.
- The Map instrument is to be found on page 12, by default.
- The Map can be placed on any page (using the Digifly **AirPages** software) and it can go from 120x120 to 240x240 pixels and any size in between.
- It is always “North up”
- The zoom is fully automatic depending on the route’s navigation requirements.
- The scale is displayed, on the lower right corner: in meters, up to 1,000 (3,300ft), and in Km over 1,000mt.
- **Map layers:**
- There are four layers available: Terrain (topography), NAV (Navigation), FAI-Triangle Assistant and Airspace CTR

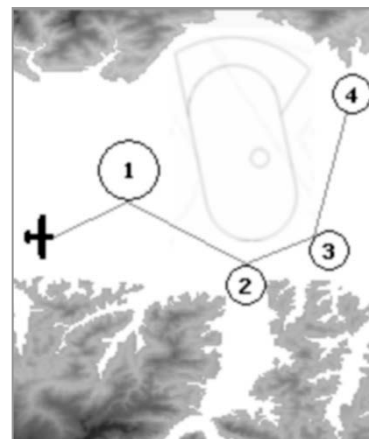

6.17.1 TERRAIN (first layer):

- This layer traces the digital elevation terrain map with 10 different shades of grey.
- With your Digifly AIR, you get FREE world wide digital topographic maps! The digital terrain elevation map files are created with the Digifly AirTools free software
- In order to view the Terrain Layer (digital elevation of the terrain) you should have previously:
a) created the digital terrain elevation map files with AirTools, using the “Maps” tab:

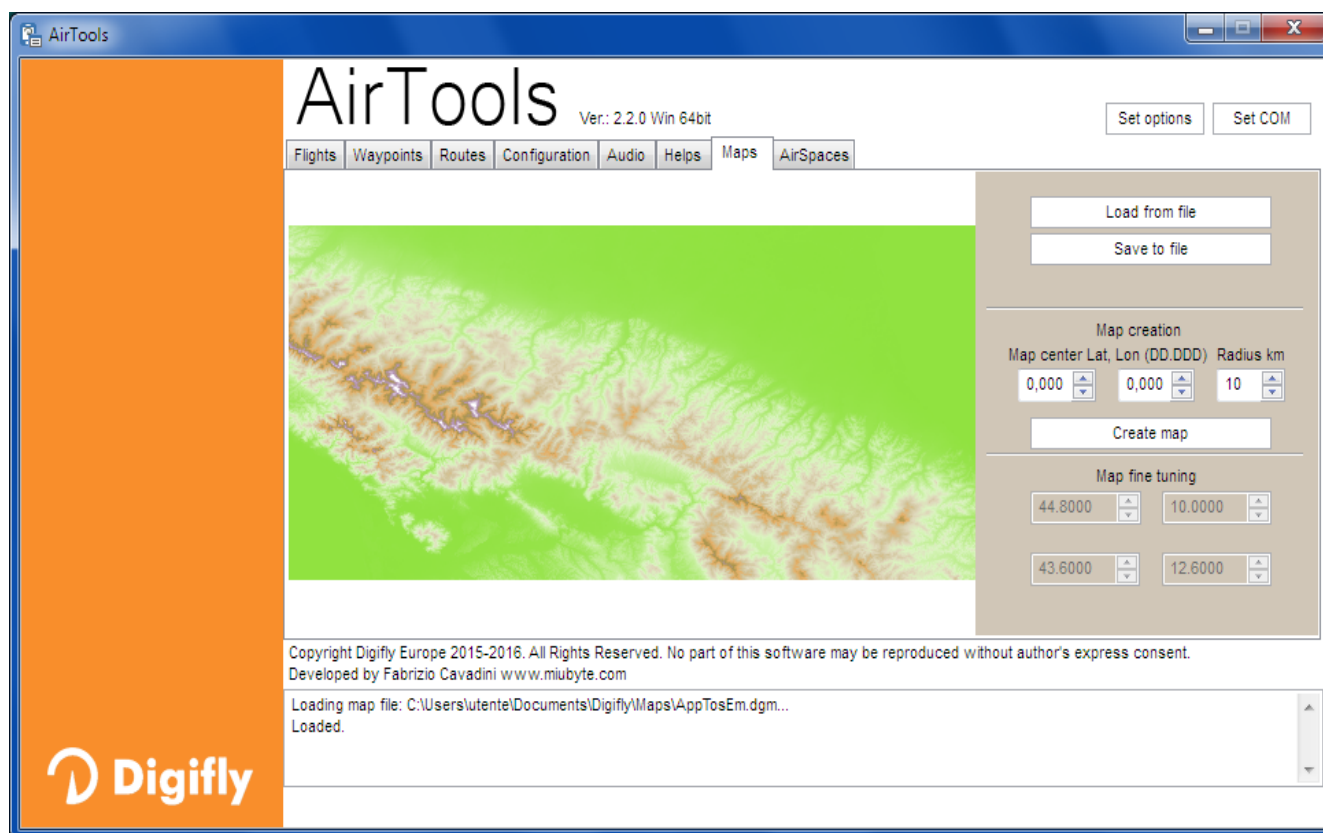

- Enter the latitude and longitude (in decimal degrees) of your desired map’s center
- Set the radius in km (e.g. 200km)
- Click on the “Create map” button. The program may prompt you to accept downloading some extra information from the Digifly website. Accept.

- Click on the “Save to file” button to save the new map file in your computer.
 - N.B.** The file name must have the xxxxxxx.dgm format, where “xxxxxxx” can be up to 8 characters.
- Close the AirTools program.
- Insert the microSD card into your computer then copy & paste the map file on the microSD.
- Remove the microSD from the computer and insert it into your Digifly Air with the instrument turned OFF.

Important notes:

- i) Use only microSD cards formatted FAT32, class 10 with at least 8GB and up to 32GB.
- ii) Insert the microSD card with the instrument turned OFF then turn it on, holding down the power key, in order to verify that the SD card is working correctly. The possible messages are: “Micro SD: OK / NONE / ERROR!” In case of error, turn the instrument off, remove the card and try it again.

Digital elevation map selection is automatic: if AGL altimeter or TERRAIN Layer are enabled, as soon as the GPS acquires coverage, the AIR will do an automatic search among the maps available on the microSD card and it will choose the one matching its current position. If you have created adjacent maps, it will also automatically connect these, even when you are in flight!

b) set the “Elevation Mode” parameter **ADVANCED SETUP \ n. 16 ELVM = 2** (suggested setting).

It defines displaying or not displaying the topography

ELVM=0: (default) = AGL altimeter disabled and Terrain Map layer disabled

ELVM=1: AGL altimeter enabled and Terrain Map layer disabled

ELVM=2: AGL altimeter enabled and Terrain Map layer enabled showing only elevations above the GPS altitude

ELVM=3: AGL altimeter enabled and Terrain Map layer enabled and it shows ALL elevations

c) set the parameter "Elevation base height" **ADVANCED SETUP \ n. 17 ELVB :**

It sets the height basis of the Terrain Map’s grayscale when ELVM is set to 3 (all elevations displayed).

In this way, you get the most out of the of 10 shades of gray color range the map uses (each shade is called a “step”), corresponding to 10 elevation contour lines.

d) set the parameter "Elevation step" **ADVANCED SETUP \ n. 18 ELVS:**



It sets the value in meters of each elevation step with a different gray scale of the Terrain Map.

From 10 to 1000m (default value 100m).

▪ Terrain Map setting examples:

When using the Terrain Map, we can define the minimum height at which the TERRAIN elevations are displayed **ADVANCED SETUP \ n. 17 ELVB** and the height corresponding to each individual step **ADVANCED SETUP \ n. 18 ELVS**.

For example, in the Fiemme Valley (Italy) with the valley floor at 1,000m (approx. 3,300ft) and maximum peaks at 3,250m (approx. 10,700ft) I can set my ELVB height at min=1,000m and ELVS step at =200m and the map will show the contour lines from 1000m up to 3000m.

- N.B. The Terrain Elevation Map is **not** displayed when the map's side is larger than 100km (62mi), when using a 240x240pixels map, or if larger than 50km (31mi), if using a 120x120 pixel map.
- N.B. It is possible to interrupt the Terrain Elevation Map's drawing by pressing the  or  buttons.
- N.B. The Terrain Elevation Map is **not** displayed when the Navigation layer is set to "NAV photo task" (see 6.17.2 for more details).

6.17.2 NAV (second layer)

- To display the NAV Layer (NAVIGATION) on your map, you need to have an active route or navigation to a waypoint.
- NAV Layer has three different layouts, switchable by **LONG PRESSING** the  button, when looking at the Map tool:
 - A) **"NAV ALL REMAINING WAYPOINTS"** (default) displays the remaining waypoints and your current position; the map is built around the waypoints you still need to tag and your current position (plane icon).
 - B) **"NAV CURRENT AND NEXT WAYPOINT"** displays the current waypoint, the one you are currently going to, the next waypoint after that and your current position: the map is built around the current waypoint, the next one and your current position (plane icon).
 - C) **"NAV PHOTO TASK"** displays the complete route, from take-off to goal, without your current position: the map is built around all the route's waypoints, including the start waypoint; **notice that** your current position (plane icon) will **NOT** be visible.

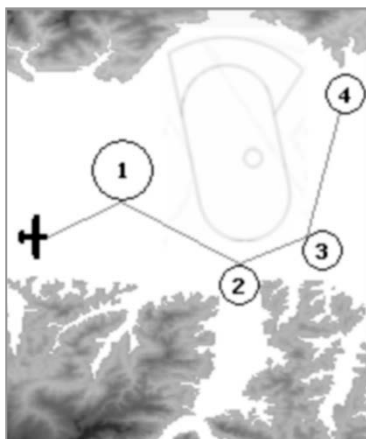

6.17.3 FAI-TRIANGLE ASSISTANT (third layer)

- The FAI-Triangle Assistant is enabled setting “ON” the parameter **ADVANCED SETUP\ n. 19 FAIT** “FAI-Triangle Assistant” (default OFF)
- Note: If you have a map on the current page (see the standard Pg.12) and the FAIT is “ON”, and have the GPS fix, the function of LONG PRESSING the  button changes and now opens a FAI-Triangle popup with choice window and timeout of approx. 4sec:



- **"Press UP to swap"**: it inverts the possible FAI-Triangle area over the task legs
 - **"Press DOWN to set V1-2"**: memorizes the current position (fix) on vertices 1 and 2 according to the following logic:
 - vertex 1 will be set automatically with the fix from take-off
 - if vertex 1 is valid and vertex 2 has not yet been memorized, then I will set vertex 2 with the current fix
 - if both vertices 1 and 2 have been memorized, then I will overwrite the vertex closest to my current position with the current fix.
 - **"Press OK to set V3"**: memorizes the current fix on vertex 3, if and only if both vertices 1 and 2 are valid.
 - **"or Menu to exit"**: by pressing the  button, you will go back to the previous screen without any modifications.
- On take-off, the FAI triangle will be re-set and vertex 1 will be automatically memorized using the position of take-off
 - The possible FAI-Triangle area is drawn if and only if the distance of the base (vertex 1, vertex 2) is at least 2km (1.2mi)
 - **FAI SIZE distance indicator**

The FAI-Triangle size distance is displayed as a numeric value, in real time, on the “**FAI SIZE**” “**FS**” instrument. This instrument has been included in the standard Pg.12

Display logic:

- Up until you take off, you will see only dashes (both vertices 1 and 2 are not yet valid)
- on take-off, vertex 1 will be automatically set with the fix
- after take-off, it will display the distance from take-off (vertex 1) until you manually set vertex 2
- after setting vertex 2 using “Press DOWN to set V1-2”, it will display the distance of the base (from vertex 1 to vertex 2) + the distance between vertex 2 and the fix
- after setting vertex 3 using "Press OK to set V3", it will display the distance of the base (from vertex 1 to vertex 2) + the distance between vertex 2 and vertex 3 + the distance between vertex 3 and the fix

Note: When the FAI-Triangle assistant is disabled, then the FAI SIZE instrument will always indicate the distance to the take-off

6.17.4 AIRSPACE CTR (fourth layer)

- This layer displays the airspaces and CTRs on your map. **Important:** this layer is **not** displayed when the Navigation layer is set to “NAV photo task” mode (see section 6.17.2).
- In order for the Digifly to draw the airspaces and CTRs, you must have previously uploaded the airspace & CTR file to the instrument’s internal memory and have correctly set the following parameters: **ADVANCED SETUP \ n. 13 CTRM** "enable CTR mode" = ON , **ADVANCED SETUP \ n. 14 CTRD** "CTR distance warning" and **ADVANCED SETUP \ n. 15 CTRH** "vertical CTR warning". Detailed instructions for this matter, are found in 6.18 and 6.18.1 below.



6.18 3D AIRSPACE MANAGER (CTR)

- The “**3D Airspace manager**” function has a very important role in air navigation especially concerning safety since it is constantly verifying -in all 3 dimensions- that our distance from the different airspaces is never closer than the safety threshold we have set, both horizontally and vertically. As soon as you pass these set thresholds, an acoustic alarm will sound and your Digifly AIR will post a warning message on your screen.
- The “**3D Airspace manager**” is managed using the following three parameters: **CTRM**, **CTRD** and **CTRH**.
 - A) “CTR Selection Mode” (**ADVANCED SETUP \ n. 13 CTRM**) set to **OFF** (default) totally disables its display and set to **ON** enables the display of the CTR layers and the proximity alarms.
 - B) "CTR Distance HORIZONTAL Warning" (**ADVANCED SETUP \ n. 14 CTRD**) should be set to the desired horizontal distance at which you want your AIR to let you know that you are getting too close to the CTR. Default setting is 400mt/1,312ft (CTRM must be set to ON and the airspace file must be in the instrument for it to work).
 - C) "CTR Vertical Distance Warning" **ADVANCED SETUP \ n. 15 CTRH** should be set to the desired vertical distance. Default 400mt/1,312ft (CTRM must be set to ON and airspace file must be in the instrument for it to work).

6.18.1 UPLOAD AND ENABLE AIRSPACE CTRs TO THE DIGIFLY AIR

- In order to be able to see the airspaces and CTRs, to activate the distance warning messages and alarms, you need to have previously done the following steps:
 - a) Search and download (Internet) the airspace and CTR files for your flying area in standard **OpenAir** format.

Websites where you can create and download your own OpenAir airspace files :

<http://airspace.xcontest.org/app/overview>

Websites where you can download ready-made OpenAir airspace files :

<http://www.lk8000.it/download/files/86-waypoints-a-airspaces.html>

<http://soaringweb.org/Airspace/HomePage.html>

<http://www.xcsoar.org/download/data.html>

OpenAir files format documentation :

<http://www.winpilot.com/UsersGuide/UserAirspace.asp>

GpsDump for PC and Android , software to edit and display OpenAir files :

<http://www.gpsdump.no/>

AirTome for PC, software to edit and display OpenAir files:

<https://bitbucket.org/airtome/airtome/downloads>

<https://bitbucket.org/airtome/airtome/wiki/screenshots>

Online converter with the option of selecting the different classes of CTRs: Converter OpenAir -> GoogleMap

<http://cunimb.net/openair2map.php>

b) Using the USB cable supplied, connect your Digifly to the PC/Mac and go to AirTools in the Digifly's Menu.

c) On your computer, open the AirTools program and click on the "AirSpaces" tab

d) Click on "Load from file", set the type of file to "OpenAir (*.txt)" on the pop up browser and select the airspace file you have; for example "ITA_N_ASP2014.txt".

Important : the file may contain up to 1000 airspaces and each airspace may contain a maximum of 500 polygon points

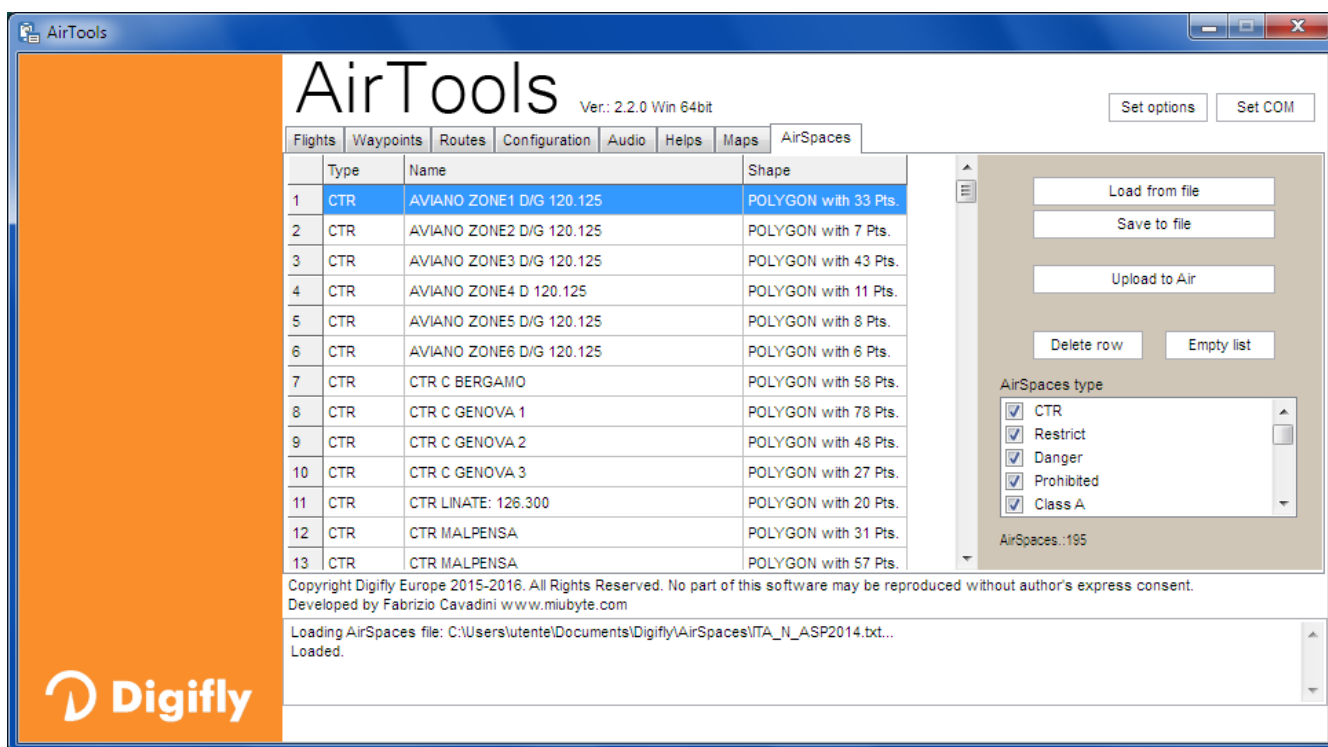

e) If applicable, deselect the airspaces that you know are not necessary (from the box on the right side)

f) Click on "Upload to AIR" to upload these files to the Digifly AIR's internal flash memory

g) Close the AirTools program

f) Set the **ADVANCED SETUP\ n. 13 CTRM parameter (CTR mode) to ON** (enable CTR)

CTRM: OFF=CTR disabled (default), ON=CTR enabled

h) Set the Distance warning (horizontal) parameter in **ADVANCED SETUP\ n. 14 CTRD (default is 400mt)**

CTRD : 0=warning disabled, from 1 to 9999= horizontal distance in mt at which the warning message and alarm will go off; this alarm will also go off if you happen to invade the airspace.

i) Set the Distance warning (vertical) parameter in **ADVANCED SETUP\ n. 15 CTRH (default is 400 mt)**

CTRH : 0=disabled, from 1 to 999=vertical distance in mt at which the warning message and alarm will go off; this alarm will also go off if you happen to invade the airspace.

6.18.2 VISUAL AND ACOUSTIC DISTANCE WARNING TO THE CTR

- Set the horizontal distance to the airspace, at which your warnings will go off, using the **ADVANCED SETUP\ n. 14 CTRD** parameter: 0=disabled, from 1 to 9999 mt=enabled (default 400)
- Set the vertical distance to the airspace, at which your warnings will go off, using the **ADVANCED SETUP\ n. 15 CTRH** parameter: 0=disabled, from 1 to 999 mt=enabled (default 400)
- When you fly inside the airspace or CTR, no matter what page you may be on, you will hear an alarm and a popup message with warning details will be displayed during 6 seconds.
- To see the last pop-up warning message, **LONG press** the  button while on page 12 (in both STD – standard andUSR – user settings); the message will be displayed during 6 seconds.
- The popup warning message and alarm will not be displayed again while you stay inside the airspace. If you fly out and then fly into it again or if you go into the MENU and back out, it will reactivate; it will **not** be reactivated if you simply switch pages.

6.18.3 CTR's HORIZONTAL DISTANCE INDICATOR

- The horizontal distance to the CTR is displayed as a numeric value, in real time, on the “**DST CTR**” instrument.



6.18.4 CTR's VERTICAL DISTANCE INDICATOR

- The vertical distance to the CTR is displayed as a numeric value, in real time, on the “**ALT CTR**”.

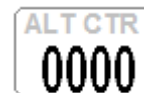



7 WAYPOINT MANAGEMENT

7.1 WAYPOINT DATABASES: COMPETITION & USER

- Competition Waypoints (“WPT COMP”) and User Waypoints (“WPT USER”); each one holds 186 waypoints.
- To visualize the Waypoint list, press the  key (“MENU” function) and select the desired WP list.
- Waypoints can be manually created or imported / exported in the following ways :
 - using a PC (via USB cable) using AirTools or GpsDump
 - using a Mac (via USB cable) using AirTools or GpsDump
 - using an Android Smartphone (via USB OTG cable or Bluetooth) using the GpsDump App
 - using another Digifly AIR via the micro SD memory card (see 12.1 Micro SD Manager)



7.1.1 MANUALLY CREATING A NEW WAYPOINT

- On the MENU screen, select the waypoint database where you’d want to save it. Highlight the first row (dotted line) then press the  key (“EDIT” function - described on sections 2.6.1 and 2.6.2).
- **Name:** 6 alphanumeric characters
- **Sym:** empty or numbers from **0 - 9** or letter **A** official landing zones (Airfield).
- **Note:** up to 16 alphanumeric characters (field below “Name”).
- **Lat. / Lon.:** Latitude and longitude.
- **Altitude:** altitude above sea level in meters
- **Radius:** radius (in meters) of the waypoint cylinder





Name	Sym
TEST	A
EXAMPLE	
Lat Lon ddmms.ss	
05 43' 46.5N	
005 43' 46.5E	
Altitude	00110 m
Radius	000400 m







7.1.2 CREATING A NEW WAYPOINT USING THE CURRENT POSITION (MARK)

- With GPS coverage, you can save the current position in the instrument’s memory using the “MARK” function.
- On the **GPS INFO** page, **LONG PRESS** the  key, the " Save Mark?" message is displayed; press the  key to confirm or the  key to cancel. The current position will be saved as a new Waypoint in the USER WAYPOINT list (“WPT USER”).

7.1.3 EDIT WAYPOINT

- To modify an existing Waypoint, scroll though the list using the arrow keys  or  until the cursor is on the desired one, then press the  key “EDIT” function - described in sections 2.6.1 and 2.6.2.

7.1.4 DELETE WAYPOINT

- To delete a Waypoint from the list, go into the desired Waypoint, then **LONG PRESS** the  key and confirm the delete request by pressing the  key, or cancel the procedure using the  key.
- To delete all the Waypoints of a list: go to the WP list **LONG PRESS** the  key, and confirm the delete request of ALL THE WP with the  key, or cancel the procedure using the  key.

8 NAVIGATE TO A SINGLE WAYPOINT (GOTO)



8.1 ACTIVATING NAVIGATION TO A WAYPOINT (GOTO)



8.1.1 NAVIGATION TO WAYPOINT HOME (GOTO HOME)

- Available only when you are on the **GPS INFO** page; it ensures that the instrument guides us back to the point where we activated this function from.







It is particularly useful, for example, when we go flying in a new site where we don't have any waypoints and we want to be guided to the official landing zone.

In this case, first go to the landing zone and activate this function from there:







From the **GPS INFO** page, with valid GPS position, **LONG PRESS** the  key; the message " Activate Home Wpt ?" is shown, press the  key to confirm or press the  key to cancel. It creates a landing waypoint in the User Waypoint list ("WPT USER") with the current position data "HOM", with the "A" (Airfield) on the "Sym" field while it activates the navigation (GOTO) to it.

Note: if the navigation function has been previously activated, first deactivate it. From the **GPS INFO** page **LONG PRESS** the  key; the message " Clear Nav ?" is shown, press the  key to confirm or  to cancel.







8.1.2 NAVIGATION TO THE NEAREST LANDING ZONE (GOTO LANDING)

- With a valid GPS position, go to the menu with the  key, select the sub-menu "Wpt Near Airfield".
- A list of the recorded landing fields ("Sym" field "A") from both WP databases (USER+COMP) is displayed.
- This list is sorted by "nearest to you," using the distance from the current GPS position.
- The cursor is automatically set on the nearest one. To choose a different one, scroll down the list (use the arrow keys  and ) , select the one you'd like to go to, **LONG PRESS** the  key, then confirm the choice to activate the navigation to this WP by pressing the  key again, or cancel the procedure using the  key.



8.1.3 NAVIGATION TO THE NEAREST WAYPOINT (GOTO NEAREST)

- With a valid GPS position, go to the menu with the  key, select the sub-menu "Wpt Nearest".
- A list of all the nearest waypoints, obtained from both USER & COMP databases, will be displayed.
- The cursor is automatically set on the nearest Waypoint. If you'd like to go to a different one, scroll the list using the arrow keys  and ) , select the new waypoint, **LONG PRESS** the  key then confirm the choice to activate navigation to the WP by pressing the  key again, or cancel the procedure using the  key.

8.1.4 NAVIGATION TO A GENERIC WAYPOINT (GOTO)

- With a valid GPS position, go to the menu with the  key, select a Waypoint database (Competition / User).
- Scroll the list using the arrow keys  ,  and set the cursor on the wished Waypoint, **LONG PRESS** the  key, then confirm activating the navigation to it by pressing the  key again, or cancel using the  key.

8.1.5 DEACTIVATING NAVIGATION TO A WAYPOINT (CLEAR NAV)



- From the **GPS INFO** page, **LONG PRESS** the  key, the message "Clear Nav ?" is shown, press  again to confirm or  to cancel.

8.2 NAVIGATION FUNCTIONS TO A SINGLE WAYPOINT (GOTO)

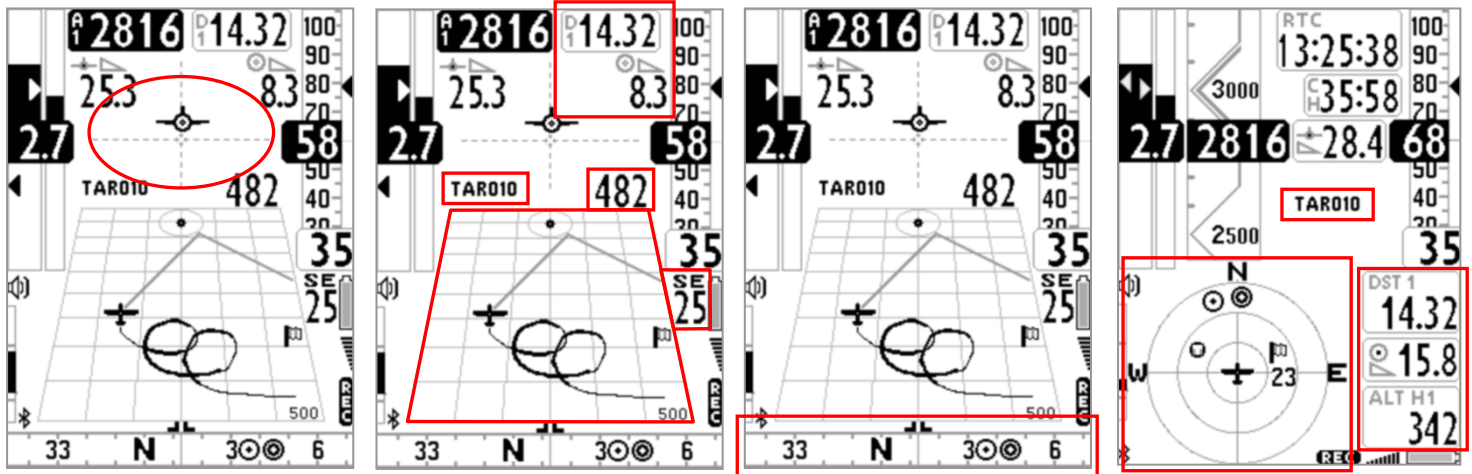
The following navigation functions are available if navigation toward a single waypoint (GOTO) is active:



8.2.1 DIRECTION , DISTANCE , EXPECTED GLIDE RATIO & HEIGHT TO THE CURRENT WAYPOINT

- **BRG 1 (B1)**: is the direction to the current Waypoint; it is shown on the compass with the  icon and the "follow me" symbol  .

BRG 1
45

- **DST 1 (D1)**: is the distance to the current Waypoint.
It can be displayed in km or in mi; go to MENU \ MAIN SETUP \ n.11 U-DS.

DST 1
14.32

- **ALT H1 (H1)**: is the estimated height of arrival to the current Waypoint.

This height is computed integrating the following information: A1 Altimeter, distance to the Waypoint "DST1", Waypoint altitude and the **expected glide ratio**.

H1 12.1
482

In order to set the expected glide ratio (glide ratio the pilot expects to have on future glides) you need to select the following parameter: **GLIDE COMPUTER SETUP \ n. 9 GLDM** :

E1
12.1

- **GLDM = "LST"** (default) :

expected glide ratio = average historic glide ratio of previous glide. The average glide ratio is continuously updated during the glide and stored in the memory during the thermal flight. To change the average time (in seconds), use the **GLIDE COMPUTER SETUP \ n. 12 EFFA** parameter.

- **GLDM = "MAN"** :

expected glide ratio = glide ratio manually set using the **GLIDE COMPUTER SETUP \ n. 10 MEFF** parameter.

- **GLDM = "AUT"** :

expected glide ratio = the estimated future glide ratio is calculated using the Polar values, the expected wind values in route to the current waypoint and presuming that the pilot will fly at best glide speeds -STF- at all times (STF considers the McCready value = 0)

Note: the value of the **expected glide ratio** being used to calculate **H1** is displayed on the top right corner of the **H1** indicator (when using "Label Top" setting) and on the **E1** indicator.

8.2.2 COMPASS TO THE CURRENT WAYPOINT

- There are two types of “Compass” instruments: a circular and linear compass and two models of the linear one. All of them will show you the direction to the current waypoint displayed with the  icon.

8.2.3 REQUIRED GLIDE RATIO TO THE CURRENT WAYPOINT

- It is the required glide ratio to reach the current Waypoint.



8.2.4 ARRIVAL HOUR, ARRIVAL TIME TO THE CURRENT WAYPOINT

- It is the expected arrival hour "TIM1 (T1)" and the expected arrival time "ETIM1 (E1)" to the current Waypoint

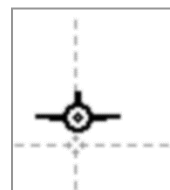

8.2.5 HSI GRAPHIC INDICATION IN SINGLE WAYPOINT MODE (GOTO)

- HSI , in single waypoint mode, is a graphical navigation tool made by two dashed lines that intersect each other, indicating the current WPT and its real height. Flying towards the center of the WPT cylinder, the airplane icon moves right or left of the dashed vertical line in reference to the route and up or down of the dashed horizontal line telling us whether, with the glide ratio calculated by the glide computer, we will arrive above or below the waypoint center.



9 ROUTE MANAGEMENT





9.1 ROUTES OVERVIEW

- From the main menu, enter in the "ROUTES" sub-menu.
- The first visualized route is the "Rt 01", to select other routes **LONG PRESS** the arrow keys  or .
- It is possible to memorize up to 12 ("Rt 01" to "Rt 12") each one containing up to 20 Waypoints.
- A route allows to automatically navigate towards the last WP (goal) passing through all the listed WPs.
- For every route, it is possible to insert waypoints from either the Competition or User banks, in any combination.
- Routes can be created manually or imported / exported in the following ways :
 - using a PC (via USB cable) using AirTools
 - using a Mac (via USB cable) using AirTools
 - using another Digifly AIR via the microSD memory card (see 12.1 MicroSD Manager)
- On the "Route" page, you will have the total route distance for both the standard and optimized route. When listed in meters: "Tot dst m" and when the distance units are set to miles, it will be displayed as "Tot dst mil" with the value in thousandths of miles. The first value shows the cumulative route's distance, depending on which waypoint you are currently highlighting and the second value is the total distance.





Rt 01	01.05	
P38 FAZ		
PRP	SSS IN	020000
P40	TP IN	000400
MND	TP IN	000400
G01	ESS IN	003000
G01	GCY IN	000400

Start Time	14 : 30	
Next Gate	20 min	
Tot. Gates	2	
Altitude	00615	mt
Dst std m	000000	085207
Dst opt m	000000	084383





9.2 VISUALIZING WAYPOINT INFO OF A ROUTE

- Using the arrow keys ,  set the cursor on the desired waypoint's line.
- Press the  key to open the drop down menu containing the possible actions, then select "EDIT - VIEW" and confirm with the  key.
- Press the  key to go back the route's page.









9.3 INSERT A WAYPOINT IN A ROUTE

- Using the arrows keys ,  set the cursor on the desired waypoint's line where you want to insert another Waypoint.
- Press the  key to open the drop down menu containing the possible actions, then select "INSERT WPT USER/COMPETITION" and confirm with the  key.
- From the Waypoints list select the desired one and confirm with the  key.

9.4 SUBSTITUTING A WAYPOINT IN A ROUTE

- Using the arrows keys ,  set the cursor on the desired waypoint's line where you want to change an existing Waypoint.
- Press the  key to open the drop down menu containing the possible action, then select "CHANGE WPT USER/COMPETITION" and confirm with the  key.
- From the Waypoints list select the desired one and confirm with the  key.

9.5 MODIFY A WAYPOINT IN A ROUTE (PARAMETER CHANGE)

- If you want a waypoint to be your "start waypoint/gate" its type must be changed (**Type = SSS**) and you may even need to adjust : **Radius, In/Out, Start Gate Time , Next Gate, N. Gates**
- Press the ,  keys to set the cursor on the desired waypoint's line that you want to modify.
- Press the  key to open the drop down menu containing the possible actions, then select "EDIT - VIEW" and confirm with the  key.
- You'll see a page with all the Waypoint's info, use the arrow keys ,  to navigate to the field you want to modify and confirm with the  key (described in chapters 2.6.1 and 2.6.2).
- The waypoint fields that are generally EDITED in a route are:
 - **Altitude** : altitude above sea level in meters
 - **Radius** : radius (in meters) of the turn point cylinder
 - **In/Out** : whether it is an "Entry" or "Exit" type waypoint.
 - **Type** (defines the waypoint's functions) :
 - TO = Take Off
 - TP = TurnPoint
 - SSS = Start of Speed Section
 - ESS = End of Speed Section
 - GLN = Goal Line
 - GCY = Goal Cylinder
 - **IF editing an "SSS" type, you need to edit the following:**
 - **Start Gate Time:** time of the first start (hours:min)
 - **Next Gate:** time interval (in minutes) between start gates
 - **N. Gates:** total number of start gates
- Press the  key to go back to the route's page

Name	Sym
P 3 8	
P 3 8	F A Z
Lat Lon ddmms.ss	
15 14' 37.9S	
047 27' 31.2W	
Altitude	00615 m
Radius	020000 m
In/Out	IN
Type	SSS
Start Time	14 : 30
NextGate	20 min
N.Gates	2

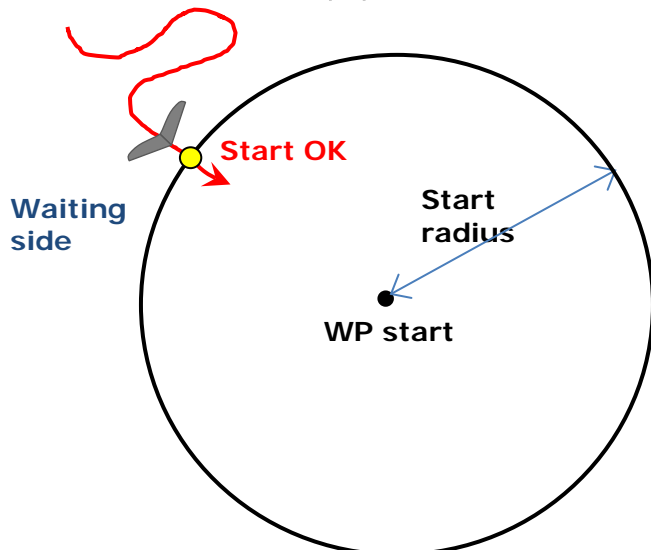

ENTRY START GATE (IN):



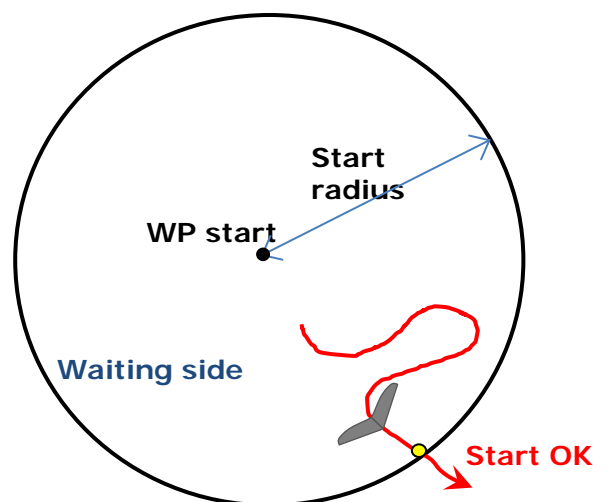

EXIT START GATE (OUT):





9.6 DELETE A WAYPOINT OF A ROUTE

- Using the arrows keys ,  set the cursor on the waypoint to be deleted.
- Press the  key to open the drop down menu containing the possible actions, then select "DELETE".

The message "Delete Wpt ?" is shown, confirm to accept the cancellation of the WP pressing the  key, or cancel the procedure using the  key.





9.7 DELETING A ROUTE

- To delete a route from the **Routes' Menu**, go into the route to be deleted and **LONG PRESS** the  key;

The message "Delete Route ?" is shown, confirm with the  key, or cancel the procedure using the  key.

10 ROUTE NAVIGATION



10.1 ACTIVATING A ROUTE

- To activate the navigation of your route, from the main menu, enter in the "ROUTES" sub-menu.
- The first visualized route is the "Rt 01", to select other routes **LONG PRESS** the arrow keys  or .
- Once you are in the route you'd like to activate, **LONG PRESS** the  key. You will see the message "Activate Route Nav ?", press the  key to confirm or press the  key to cancel.

Important: when you activate the route, a window with the summary of the most important settings of your route will pop up to allow for a settings check before the competition starts:

- **Date and local time:** check the UTCO setting is correct = time zone + summer or winter time
 - **IFLY = OFF / CMP / XC:** current setting of the automatic page switcher "Intellify"
 - **DTOL = x.x %:** tolerance percentage used by the distance calculator
 - **DCAL = FAI Sphere / WGS84:** mathematical model of the earth used by the distance calculator
- A route allows to automatically navigate towards the last WP (goal) passing through all the listed WPs. The "Real Time Navigation Manager / Skip waypoint" function shows the navigation progress of the active route in real time and allows you to choose to navigate to a different waypoint (see section 3.9.8).

10.2 DE-ACTIVATING A ROUTE (CLEAR NAV)

- From the **GPS INFO** page, **LONG PRESS** the  key, the message "Clear Nav ?" is shown, press the  key to confirm or press the  key to cancel.

10.3 OPTIMIZED NAVIGATION

- Route navigation is continuously optimized and recalculated every second in real time, indicating the shortest path along the route :

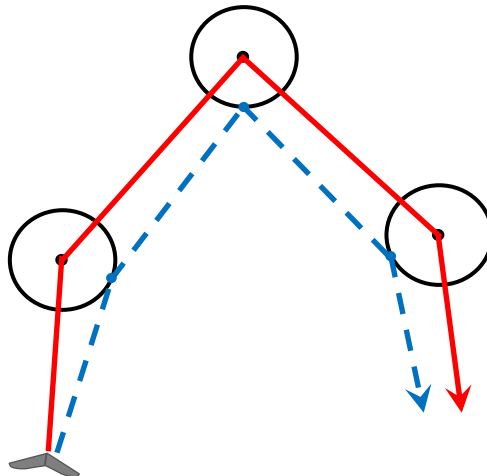



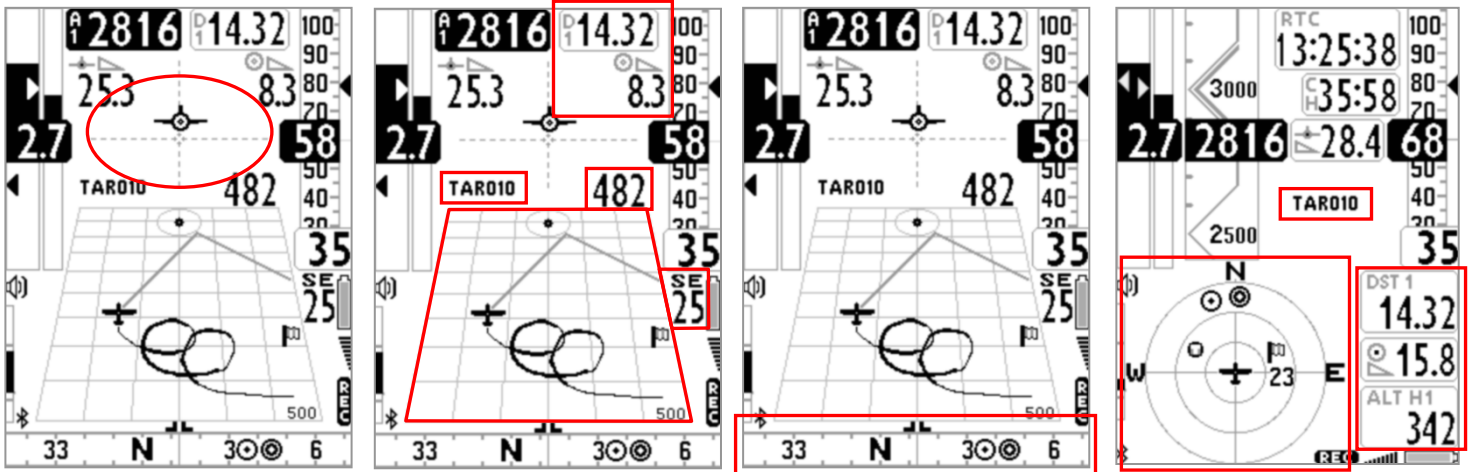
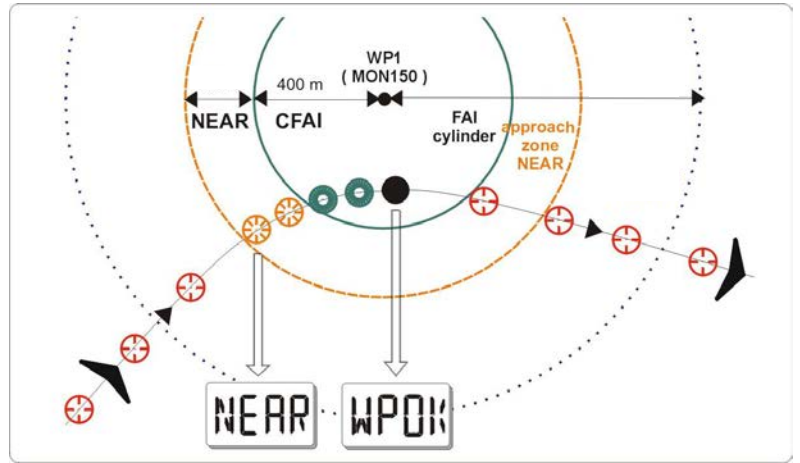

10.4 NAVIGATION TO A STANDARD WAYPOINT

- If the current Waypoint is **not** set as a start waypoint, the navigation is managed in standard cylinder mode and the Digifly AIR will guide you providing constant information about your position, distance, direction, required glide ratio and expected arrival height above the current Waypoint cylinder and to the arrival Waypoint cylinder (goal).
- When you get near the Waypoint cylinder (100mts), the flight recorder rate is automatically set to one data point per second (oversample).
- Cylinder validation: when you enter a cylinder the Digifly AIR will alert you with a sound and you will see a message of "WPOK" (or "TASK FINISHED" if it is the arrival Waypoint), then the flight recorder rate returns to the setup value (MAIN SETUP \ n.6 RECR).
- If the navigation is activated the following functions are visible:



10.4.1 DIRECTION , DISTANCE , EXPECTED GLIDE RATIO & HEIGHT OVER THE CURRENT WAYPOINT

- **BRG 1 (B1):** Shows direction to the current waypoint cylinder along the optimized route. It is represented by the  icon on the compass and with the  "follow me" icon. 
- **DST 1 (D1):** Shows the distance to the current cylinder waypoint along the optimized route. It can be displayed in km or in mi; go to MAIN SETUP \ n. 11 U-DS. 
- **ALT H1 (H1):** Shows the estimated arrival height to the current cylinder waypoint along the optimized route. This height is computed integrating the following information: A1 Altimeter, distance to the current cylinder waypoint "DST1", current waypoint altitude and the **expected glide ratio**.

In order to set the expected glide ratio (glide ratio the pilot expects to have on future glides) you need to select the following parameter: GLIDE COMPUTER SETUP \ n. 9 GLDM :

- **GLDM = "LST"** (default) :

expected glide ratio = average historic glide ratio of previous glide. The average glide ratio is continuously updated during the glide and stored in the memory during the thermal flight. To change the average time (in

seconds), use the **GLIDE COMPUTER SETUP \ n. 12 EFFA** parameter.

- **GLDM = "MAN" :**

expected glide ratio = glide ratio manually set using the **GLIDE COMPUTER SETUP \ n. 10 MEFF** parameter.

- **GLDM = "AUT" :**

expected glide ratio = the estimated future glide ratio is calculated using the Polar values, the expected wind values in route to the current waypoint and presuming that the pilot will fly at best glide speeds -STF- at all times (STF considers the McCready value = 0)

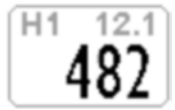

Note: the value of the **expected glide ratio** being used to calculate **H1** is displayed on the top right corner of the **H1** indicator (when using "Label Top" setting) and on the **E1** indicator.

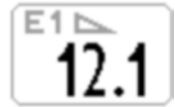



- **BRG 0 (BO):** Shows the direction to nearest point of the current waypoint cylinder; also, shown with the  icon on the compass.

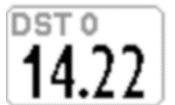

- **DST 0 (DO):** Shows the distance to the nearest point of the current waypoint cylinder.



10.4.2 COMPASS TO THE CURRENT WAYPOINT

- There are two types of "Compass" instruments: a circular and a linear compass and two types of linear ones. All of them display the direction to the optimized point of the cylinder (optimized route) using the  icon. It also displays the direction towards the nearest point on the cylinder with the  icon.

10.4.3 REQUIRED GLIDE RATIO TO CURRENT WAYPOINT

- It is the required glide ratio to reach the current Waypoint's cylinder along the optimized route.



10.4.4 ARRIVAL TIME & TIME TO CURRENT WAYPOINT

- "**TIM1 (T1)**" shows the estimated arrival time to get to current cylinder waypoint along optimized route and "**ETIM1 (E1)**" shows how much remains until the estimated arrival time.

10.4.5 HSI GRAPHIC INDICATION IN ROUTE MODE

- HSI , in route mode, is a graphical navigation tool made by two dashed lines that intersect each other. During the flight, the airplane icon moves right or left of the dashed vertical line in reference to the center of the current WPT cylinder and up or down the dashed horizontal line telling us whether, with the glide ratio calculated by the glide computer, we will arrive above or below the goal waypoint cylinder.

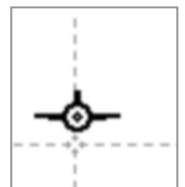

10.4.6 DISTANCE , EXPECTED GLIDE RATIO & HEIGHT OVER THE ARRIVAL WAYPOINT (GOAL)

- **DST A (DA)**: Shows the distance to the goal along the optimized route.

A digital display showing 'DST A' in small letters above the large number '44.52'.

- **ALT HA (HA)**: Shows the estimated height above the goal , along the optimized route. This height is computed integrating the following information: A1 Altimeter, distance to the goal along the optimized route "DST A", altitude of the goal waypoint and the **expected glide ratio**.

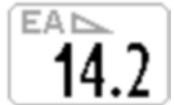
A digital display showing 'HA' in small letters, '14.2' in medium letters, and '42' in large letters.A digital display showing 'EA' in small letters with a small triangle icon to its right, and the large number '14.2'.

In order to set the expected glide ratio (glide ratio the pilot expects to have on future glides) you need to select the following parameter: **GLIDE COMPUTER SETUP \ n. 9 GLDM** :

- **GLDM = "LST"** (default) :

expected glide ratio = average historic glide ratio of previous glide. The average glide ratio is continuously updated during the glide and stored in the memory during the thermal flight. To change the average time (in seconds), use the **GLIDE COMPUTER SETUP \ n. 12 EFFA** parameter.

- **GLDM = "MAN"** :

expected glide ratio = glide ratio manually set using the **GLIDE COMPUTER SETUP \ n. 10 MEFF** parameter.

- **GLDM = "AUT"** :

expected glide ratio = the estimated future glide ratio is calculated using the Polar values, the expected wind values along the route to the goal waypoint and presuming that the pilot will fly at best glide speeds -STF- at all times (STF considers the McCready value = 0)

Note: the value of the **expected glide ratio** being used to calculate **HA** is displayed on the top right corner of the **HA** indicator (when using "Label Top" setting) and on the **EA** indicator.

10.4.7 REQUIRED GLIDE RATIO TO GOAL

- It is the required glide ratio to reach the goal, along the optimized route.

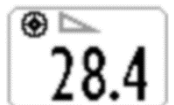
A digital display showing a small triangle icon above the large number '28.4'.

10.4.8 ARRIVAL TIME & TIME TO GOAL

- **"TIMA (TA)"** shows the estimated arrival time to get to the arrival waypoint along optimized route and **"ETIM A (EA)"** shows how much remains until the estimated arrival time.

10.4.9 CROSS TRACK ERROR (XT)

- This instrument displays your lateral deviation regarding the NON-optimized route. Showing your distance from the line joining the centers of the two waypoints (past and current). If you are to the right side of the line, it will be displayed in black over white, if you are to the left side of it, it will be displayed in reverse (white over black).
- **Remember:** when creating your own pages (with AirPages), leave the border of this instrument; otherwise, the reverse function will not work. It will **ONLY** display black over white (not showing you are flying left of the route).

A digital display showing 'DST XTE' in small letters above the large number '0000'.

10.5 NAVIGATION TO THE START WAYPOINT (GATE)

- The current Waypoint is managed as a Start waypoint only if its parameter **Type** has the value “SSS” (Start of Speed Section - see 9.5).
 - The crossing direction of the Start Waypoint line is established by its parameter **In/Out** :
“IN” = Entry start Waypoint (Entry) , “OUT” = Exit Start Waypoint (Exit). (see 9.5).
 - When the first start gate time is 10 minutes away, a message appears on the screen: “10 MIN TO GO !” followed by a double beep.
 - When the time to the start gate is 00:00, the “GATE OPENED” message appears on the screen, followed by a double beep, telling the pilot that the gate is open and he can now go through the start waypoint (IN or OUT depending on the selected option).
 - When you go through the start waypoint before the gate is opened, the value of the distance to the cylinder line is shown in reverse mode (white on black background) so that you know you’re on the other side of the circle.
 - The instrument guides us constantly towards the border of the “start waypoint”, until it gets crossed correctly when it opens. When this happens the “WP OK” message appears, followed by a bitonal sound.
-
- **IN** = start validation entering the cylinder **OUT** = start validation exiting the cylinder.

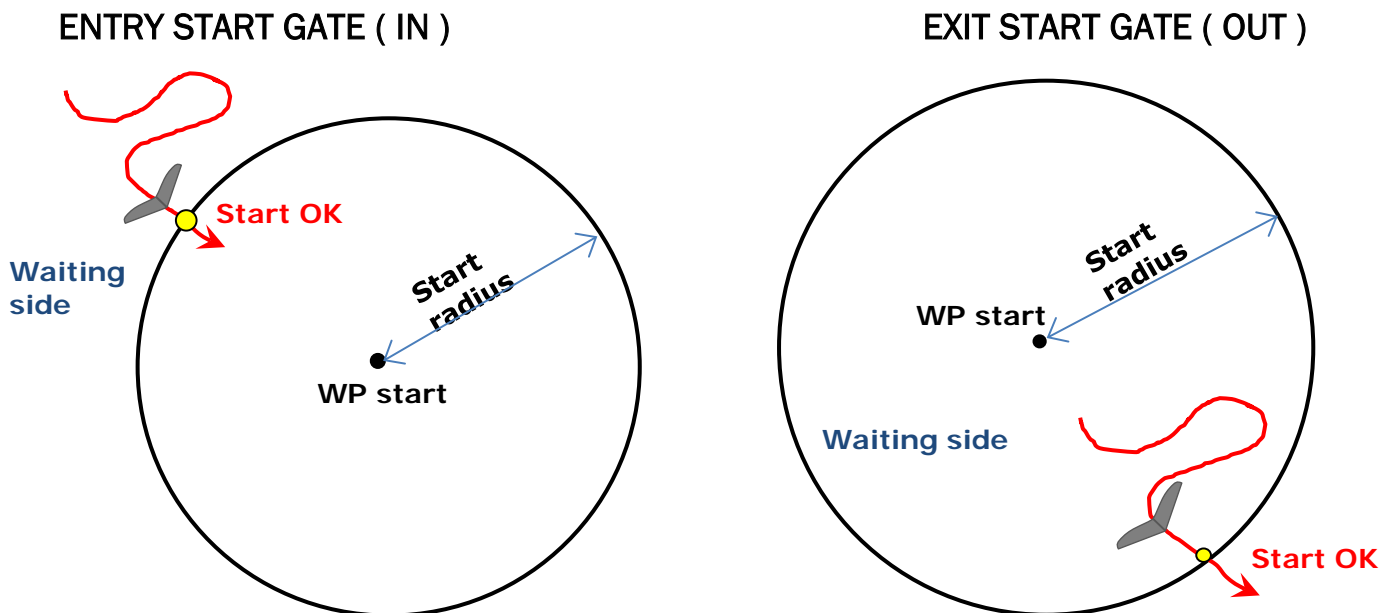

10.5.1 STARTING TIME (TSTART)

- **TSTART:** Shows the start gate time.

To choose a different start gate time, see section 10.5.5 below.

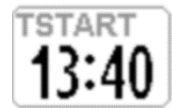

10.5.2 REMAINING TIME TO START (CSTART)

- **CSTART (CS):** shows time remaining (countdown) until the start gate opens

To choose a different start gate time, see section 10.5.5 below.



10.5.3 EXPECTED ARRIVAL TIME TO START LINE (ESTART)

- **ESTART (ES):** Shows the estimated arrival time to the edge of start cylinder, based on the average speed relative to the countdown. If the instrument indicates "00:10" (black on white), it means the pilot will get to the start line with a delay of 10 seconds; if its written "00:15" in reverse mode (white on black), it means the pilot will get to the start line 15 seconds ahead of time (penalty).





10.5.4 REQUIRED SPEED TO START THE CYLINDER LINE (STS)

- **STS (SS):** shows the required speed to get to the start cylinder line in time for gate opening.





10.5.5 CHOOSING A DIFFERENT START GATE TIME IN A COMPETITION ROUTE



- Once the route is activated, all these parameters refer to the first start gate time. If you decide to take a different start (when there are multiple start gates), you need to short press the  button once -on any of the navigation pages (it won't work from the "INFO GPS" page)- in order for the values to update to the new start gate time. Every time you short press the  button, you will move one clock forward and, if you are on the last one, you will jump back to the first one.

10.6 SKIP WAYPOINT SHORTCUT

- The "Skip Waypoint" function of a route (no shortcut - from "Info GPS" page) is explained on paragraph 3.9.8
- The Digifly AIR also has a shortcut for this function, from any of the navigation pages. In order to activate it, the "Skip Waypoint Shortcut" parameter (**ADVANCED SETUP \ n 22 SKPW**) needs to be set to ON.

Keep in mind that this will change the functions of some buttons:

With the parameter set to **OFF** = Shortcut disabled (default), **LONG PRESS** the  button changes the volume level and **LONG PRESS** of the  button sets the A2 altimeter to zero.

However, with the parameter set to **ON** = Shortcut enabled and, when a route is activated both for competition or XC, **LONG PRESS** the  and  buttons, will respectively work as skipping a waypoint back and forward buttons, without having to go to the Info GPS page first.

10.7 OPERATION CHECKLIST BEFORE A TASK

- Be sure that batteries are fully charged.
- Ensure the **IFLY** parameter (**MAIN SETUP \ n. 27**) is set to CPA = automatically switches between the 4 competition pages (see section 3.2.3)
- Make sure the competition-specific pages (Pg01 to Pg04) are active (see section 3.3)
- Verify that parameter **A1AL** (**ADVANCED SETUP \ n. 10**) is set correctly = max. **A1** altitude (see section 4.1.4)
- Ensure the correct setting of parameter **DCAL** (**GLIDE COMPUTER SETUP \ n. 2**) = FAI Sphere / WGS84: mathematical model of the earth used by the distance calculator (see section 6.4)
- Make sure parameter **DTOL** is set correctly (**GLIDE COMPUTER SETUP \ n. 1**) = x.x % : tolerance percentage used by the distance calculator (see section 6.5)
- Download the waypoints from the competition's official web site or get them from the scorekeeper.
- Upload them to the Digifly Air using AirTools via USB cable (PC, Mac) , GPSDump via USB cable (PC, Mac, Android Smartphone) , GPSDump via Bluetooth (Android Smartphone) or with another Digifly AIR using a microSD memory card and the microSD manager
- Edit the route accordingly to the information on the taskboard:
 - Insert the cylinders' radii
 - Set the type of waypoint correctly in the "**Type**" field, remember to set the Start waypoint to "**SSS**" (Start of Speed Section – see paragraph 9.5).
 - Specify whether the waypoint has an Exit or an Entry cylinder around it using the field "**In/Out**": "**IN**" (cross the line as you enter the cylinder) or "**OUT**" (cross the line as you exit the cylinder).
 - Insert the start time correctly
 - For multiple start gates (SG), insert the SG interval and Number of SG.
 - In the route page verify that the total distance corresponds ("Tot dst m"), it is calculated from the center of the first waypoint to the center of the last waypoint along the standard route (not optimized).
- Activate the route : **LONG PRESS** the  key and confirm.

Important: when you activate the route, a window with the summary of the most important settings of your route will pop up to allow for a settings check before the competition starts:

- **Date and local time** : check the correct setting of UTCO = time zone + summer or winter time
 - **IFLY** = OFF / CMP / XC : current setting of the automatic page switcher "Intellifly"
 - **DTOL** = x.x % : tolerance percentage used by the distance calculator
 - **DCAL** = FAI Sphere / WGS84 : mathematical model of the earth used by the distance calculator
- Set the barometric A1 Altimeter, this is important as it is also used by the glide computer.
 - Before takeoff, turn your instrument on, with enough time to allow a correct GPS position to be acquired.
 - After the GPS position has been acquired, check that the time is correct. If necessary, change the time zone setting, otherwise the start time will be wrong. Parameter: **MAIN SETUP \ n.7 UTCO**

11 FLIGHT RECORDER

- When the Digifly Air starts the flight recorder, it shows the “REC ON” message and the “rec”  icon, on the bottom of the display, starts blinking. The following parameters are continuously recorded: Date and time, latitude, longitude, fix status, barometric altimeter QNE , altimeter GPS, number of satellites, GPS ground speed, anemometer, variometer and barometric A1 altimeter.
- The Recorder adds a barometric point to the recorded track even when there may be a temporary gap in GPS coverage (according to the **FAI-CIVL Cat 1** regulations).
- **IMPORTANT:** while in menu no data is recorded.

11.1 ACTIVATING / DE-ACTIVATING THE FLIGHT RECORDER

- The flight recorder can operate in three different ways:
 - “AUT”: Automatic flight recorder.
 - “ALW”: Flight recorder always active
 - “OFF”: Flight recorder deactivated.

11.1.1 RECORDING MODE: AUTOMATIC START “AUT”

- Default setting. The flight recorder starts automatically, **MAIN SETUP \ n.3 RECM = AUT**
- The flight recorder activates automatically when: the GPS position is available and it has detected a takeoff with an altitude variation of at least 0,5m (**MAIN SETUP \ n.4 R.DS = 0,5**) and Ground Speed (GPS) higher than 6km/h (3.7 mph) for 3 consecutive seconds (**MAIN SETUP \ n.5 R.TI = 3**).
- **PRE-RECORDER** (according to the **FAI-CIVL Cat 1** regulations)
When you take off, the recorder will include, at the beginning of the flight log, the 30 trackpoints prior to the take-off (pre-recorder).
Before taking off, you need to make sure the recorder has been able to get at least 30 trackpoints (=30 seconds). While the instrument records these 30 points, you will see a black rectangle in place of the recorder’s icon.
- The flight recorder is automatically deactivated 60 second after landing or if the instrument is turned off.



11.1.2 RECORDING MODE: ALWAYS ACTIVE “ALW”

- To set the "Always Active" record mode, set the **MAIN SETUP \ n.3 RECM** parameter to “ALW”. The flight recorder is activated once the instrument is turned on and is deactivated when it is turned off.





11.1.3 RECORDING MODE “OFF”

- To deactivate the flight recorder set the **MAIN SETUP \ n.3 RECM** parameter to “OFF” (no data is recorded).

11.2 RECORDING RATE

- The recorder rate can be adjusted from 1 to 60 seconds, go to: **MAIN SETUP \ n.6 RECR**).
- Setting 1 data point per second, will record over 30 hours of flight data.
- Setting 1 data point per minute, will record up to 1800 hours of flight data.
- The recorder memory has room for up to 100,000 GPS data points and up to 250 flights.
- When you are 100m from a Waypoint, the recorder rate is automatically increased to 1 data point per second.
- When the recorder's memory is full, the oldest flight is automatically deleted by the newest one.
- The remaining free memory time and percentage are shown for 2 seconds as the instrument is turned on, or for as long as the power button is pressed when turning the instrument on.
- If a single flight fills the whole memory, it is not possible to use the recorder anymore. The "MEM FULL" message appears every time that you try to use it. To activate the flight recorder again, it is necessary to clear the entire recorder memory. To do this: go to **MENU \ LOGBOOK LONG PRESS** the key  and confirm the cancellation of ALL FLIGHTS by pressing the  key, or cancel the procedure using the key .

11.3 LOG BOOK MANAGEMENT (LOG BOOK)

- To see the recorded flights, select the menu "LOGBOOK". The list of all the recorded flights will be displayed with their date and take off time.
- To see details of each recorded flight, select a flight the press the  key. For every flight the following information is displayed:
 - Take off date and time, flight duration, and total altitude gain.
 - Max. and min. values for A1 Altimeter and Variometer
 - Max values for Ground speed GPS and Indicated Airspeed (IAS)
- To delete all the flights : from the menu "LOGBOOK LONG PRESS" the  key and confirm the cancellation of ALL THE FLIGHTS by pressing the  key, or cancel the procedure using the  key.
- It is not possible to delete a single flight.
Suggestion: It is a good practice to clear up your flight memory before the start of a competition. You can save your flights on your computer before doing this.

11.4 INTEGRATED IGC FILE

- INTEGRATED IGC FILE (formatted according to the **FAI-CIVL Cat 1** regulations)
Automatically generates an IGC file with G-Record signature directly on the microSD card, in the \IGC folder. If the folder is not yet on the microSD, it will be created automatically.
- How to use: Go to Menu \ Logbook, select the desired flight, then LONG PRESS the  button.
- The help message under "Logbook" will say "long press OK to save IGC"

12 ADDITIONAL MEMORY CARD

- On the Digifly AIR's housing, you will find the **microSD Class 10** memory card reader slot, with a capacity ranging from 8GB to 32GB formatted FAT32.
 - To insert a memory card, your instrument must be OFF. Place the card with the label facing the instrument's keyboard side and insert the card's connector side in the instrument; to lock the memory card it is necessary to gently press it with your fingernails (or another microSD) until it you hear the typical "locked" click.
 - To extract the memory card, turn your instrument OFF, press the SD card and let it go, to release it.
- Warning:** Beware that if the card is inserted incorrectly, it could damage the instrument void its warranty.
- You will use this card to store the topographic map files, as many as you want, that your AIR will use for the map instrument. With the microSD card containing map files in your AIR, when you turn it on and it acquires GPS signal, the AIR will automatically search those files and select the ones relevant to the place it finds itself in.

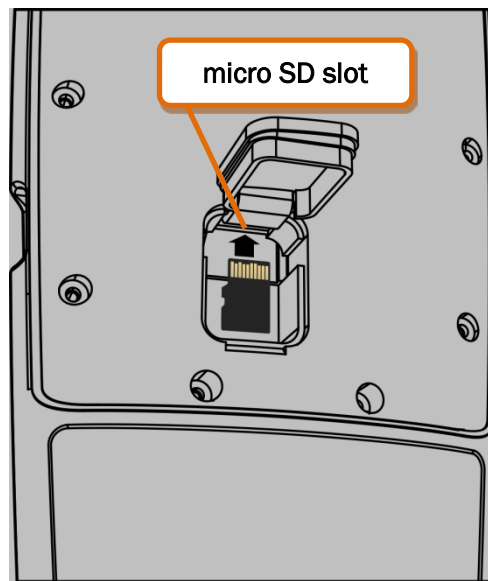

12.1 MICRO SD MANAGER



- The "MicroSD Manager" enables transferring data from one Digifly AIR to another using a microSD card (e.g. waypoints, routes, pages and sound profiles).
- On the Main Menu scroll down then select "microSD Manager" and choose the function you would like to access:

- Route Import
- Route Export
- Wpt Comp Import
- Wpt Comp Export
- Wpt User Import
- Wpt User Export
- Audio Import
- Audio Export
- Page Import
- Page Export
- File Explorer
- Auto Import

- The directory structure, created automatically is as follows :

\ROUTES (*.TSK)	ROUTE-01.TSK ... ROUTE-12.TSK
\WAYPOINT (*.WPB)	WPT-COMP.WPB, WPT-USER.WPB
\AUDIO (*.DGA)	AUDIO-01.DGA, AUDIO-02.DGA
\PAGES (*.PAG)	PAGE-01.PAG ... PAGE-12.PAG

- “File Explorer” function :

- Use arrows to highlight a directory, then the  button to access it
- LONG PRESS the  button to return to the main directory
- Exit using the  button

- “Auto Import” (from microSD) function :

This function is very helpful to automatically import all the files in the microSD’s \AUTOIMPO folder.

For example, it is possible to upload the new help file directly to your instrument, the steps are as follow:

- Correctly insert the microSD on your PC/Mac/Smartphone.
- Create a folder named \AUTOIMPO and copy the help files you want to upload to the new folder, in this example, it would be the U246_Help_UK_v1_Air704.CCC
- Remove the microSD from your PC/Mac/Smartphone.
- Ensure that your Air is turned OFF and the microSD is in the correct position before inserting it.
- Turn your Air ON, then go to MENU and to the “microSD Manager” function.
- Enter the “Auto Import” submenu and press the  button.
- Once the instrument is done uploading the files, it will automatically return to the “microSD Manager” function.
- Exit the menu page and go back to the instrument’s regular pages.

13 CONNECTIONS & INTERFACES

- It is possible to connect your Digifly AIR-PRO to a PC, Mac, Smartphone, Tablet, PDA, etc. using the provided USB cable or with a wireless connection via Bluetooth.

13.1 USB CABLE CONNECTION

- Connecting to an Android Smartphone via USB cable does not require a driver installation; just use a simple USB-OTG (On-The-Go) adapter.
- Instead, in order to use the USB connection with a PC or MAC, the FTDI driver must be installed.
- **USB cable driver automatic installation**
Connect the USB cable to the PC/Mac and to the instrument, while connected to the Internet and the operative system will usually download and install the FTDI driver automatically.

- **USB cable driver manual installation**

If the automatic installation is not successful, you need to manually install the FTDI driver:

- Disconnect the USB cable from the PC/Mac and from the instrument
- Download the proper driver installation program accordingly to the PC/Mac in use from www.digifly.com -> download -> FTDI USB Cable Driver.
- Find your computer system on the chart and choose the driver on the far-right column (under comments).
- Unzip the downloaded files and run the driver installation program.
- Restart your computer and reconnect the USB cable to the computer and to the instrument.

- **Verify proper installation of the USB driver:**

- Connect the USB cable to the PC/Mac
- For example, from Windows7, go to Start -> Control Panel -> System and Security -> System -> Device Management.
- Click on the “+” sign next to "Ports (COM e LPT)".
- If the driver is correctly installed, you will see the "USB Serial Port (COM X)" without any yellow indication of error. **Note:** The 'X' is the number of the COM port assigned to the computer's USB.
- The driver type is visible with a right click on your mouse over "USB Serial Port" then click on “Properties”; if the driver is installed it will show “FTDI”.

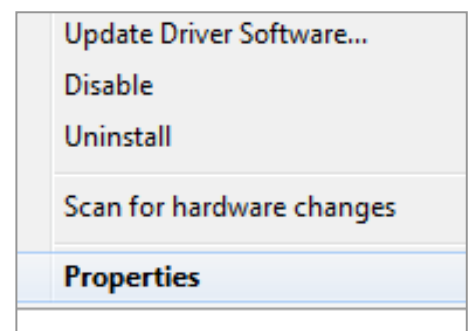
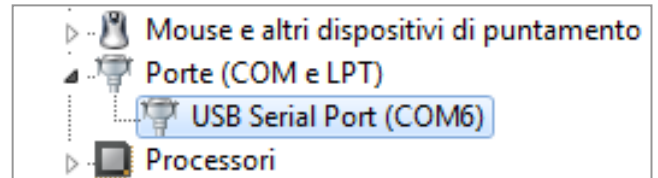

- **How to manually reassign the COM port number:**

- All Digifly software performs the automatic search of the COM port in the range of 1 to 20; a third-party software in most cases requires that the COM port is in the range from 1 to 9.
If the COM port assigned by the computer has a higher number it is necessary to manually reassign it:
- Connect the USB cable to the PC/Mac
- Right click on "USB Serial Port" then click on “Properties”

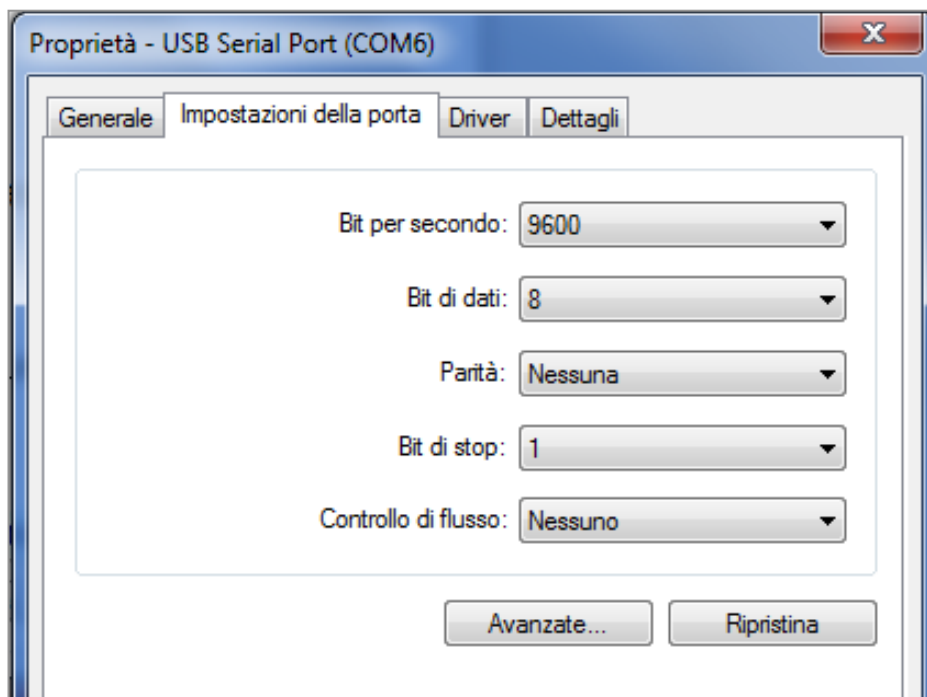

- o Click on "Port settings" then click on "Advanced"
- o In the "Advanced Settings" window, set the "COM Port Number" with the lowest number (from 1 to 9) among the ports that aren't already in use, then click "OK"

Note: If the value displayed on the "Device Manager" window is still the old one, refresh the display value by closing and reopening this window

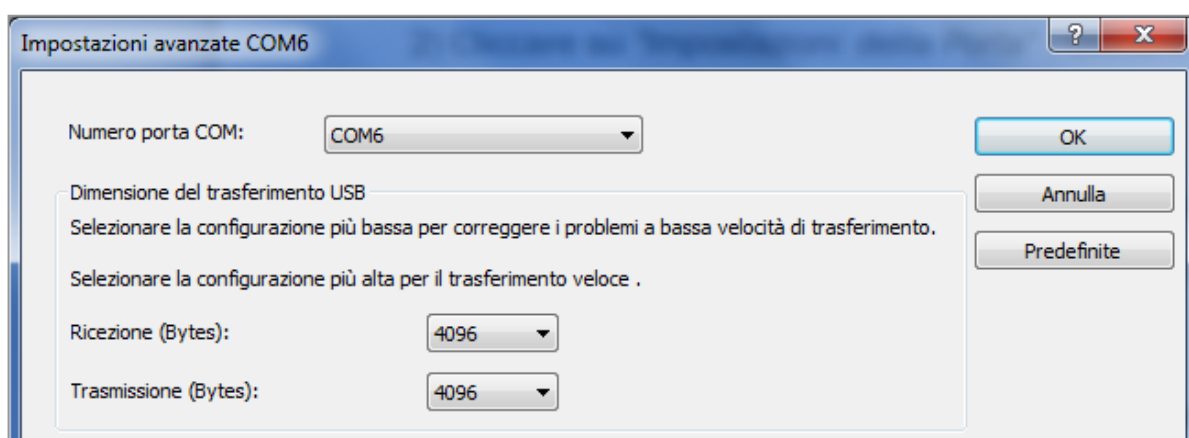

- o Take note of the COM port number, to be used later on to manually set the correct port number of third-party software (e.g. GpsDump).

Please note that all Digify software has automatic COM port number detection (Auto-search) and therefore it does not need this setting.

13.2 BLUETOOTH CONNECTION

▪ New Bluetooth 4.0 Low Energy Dual Mode SPP / BLE Features

The Digifly AIR-PRO instruments are equipped with a “Bluetooth 4.0 Low Energy Dual Mode SPP / BLE” module. When the instruments are turned on, the launch page will display the type of Bluetooth module: “Bluetooth 4.0”

The “Bluetooth 4.0 Low Energy Dual Mode SPP / BLE” module provides the maximum flexibility of use and allows communication both in “Classic” and “Low Energy” modes.

Classic Mode: it is the standard mode and uses the SPP (Serial Port Profile) communication profile

Low Energy Mode: this modes requires less energy to run and uses the BLE (Bluetooth Low Energy) communication profile

New “Clear all paired” option added, which allows to delete are previous pairings.

▪ New Automatic BLE Bluetooth Connectivity with FlySkyHy (iPhone) and XTrack (Android)

Being equipped with a Bluetooth BLE module, allows the Digifly Air to automatically connect to an Apple iPhone or iPad as well as to an Android Smartphone or Tablet.

How to communicate using the automatic Bluetooth BLE communication mode:

- On your Digifly Air go to Menu \ Advanced settings and set the following parameters as shown below:

TGPS=1, TAIR=DGF, TFRQ=3, TCHA=BLE, TAUT=ON, T-ID=1

- On the FlySkyHy or XTrack Apps, select "Digifly" from the list of external Bluetooth devices and then set both GPS and Barometric Data to “external”

▪ The communication possibilities offered by the fully functional Bluetooth System on the Digifly AIR-PRO are extraordinary and practical! There are two major lines to use your Bluetooth:

1) Upload and download waypoints and tracklogs between your instrument and an external device using GPS Dump Android version.



2) The second option, which really marks a difference and, once more, shows the quality of this instrument is that the Digifly AIR-PRO has an integrated **Digi-FLYBOX** (Telemeter). This feature allows your Digifly AIR-PRO to send its telemetry (data from its sensors: barometric altitude, GPS altitude, ground speed, IAS speed -with Pitot Tube system-, variometer, GPS position, etc.), in the international NMEA format via Bluetooth or via USB cable, to another device (E-Reader, Smartphone and Tablet) it has previously paired with, so that this data can be used directly by specialized programs such as LK8000, XCSoar, XTrack, Top Hat, GpsDump, TTLiveTrack24, Flyskyhy.

It is possible to communicate also with certain iPhone Apps (ex. Flyskyhy) using "Bluetooth BLE" mode.

The telemetry can also be used to **live track** to any server using, for example, GpsDump or TTLiveTrack24 on a Smartphone.

This means that the Digifly AIR-PRO is also a **Telemeter** and in Digifly we call this the Integrated **Digi-FlyBox** ; other companies call this function an “Info Box / Data Source / Sensor Box”, but none of these will include an anemometer (Pitot Tube System) like our instrument does.

13.2.1 BLUETOOTH SPP (Bluetooth Classic) "PAIRING"





- The communication via Bluetooth SPP (Bluetooth Classic) between Digifly AIR-PRO and an external device (Smartphone , Tablet and E-Reader) is possible only after pairing the two devices, here is how to proceed:
 - 1) On the **AIR**, set the **ADVANCED SETUP \ n. 29 ACHA** parameter to "**SPP**"
 - 2) Enter the MENU page and go to "**AirTools**", you will be prompted to choose one of the following options:
 - “Press (UP) to clear pair”: any previous pairing will be deleted
 - “Press (DOWN) to link BT”: to communicate via Bluetooth
 - “Press (OK) to link USB”: USB cable data transmission will be enabled
 - “or (Menu) to exit” : returns to the previous menu
 - 3) press the  key.
 - 4) **AIR** looks forward to the pairing request from the external device.
 - 5) From the Bluetooth’s control panel of the external device, press the option "Search".
 - 6) A list of available devices is created, select "Digifly Air nnn" (where “nnn” are the last three digits of your instrument’s serial number).
 - 7) If prompted, enter the pairing code of the AIR which is "**0000**" and then confirm; if the procedure is successful, the external device displays a message confirming that the Digifly AIR-PRO is paired.
- Once the AIR has paired with a device, it is no longer necessary to repeat the pairing process.
- In case of problems, press the  key on the **AIR** to exit and try it again.

14 SOFTWARE

14.1 AIR MANAGEMENT SOFTWARE

- Your Digifly Air uses the Digifly protocol, which enables high speed communication with the applications having it embedded in their interface (e.g. AirTools, AirPages and GpsDump); thanks to this protocol it is possible to remotely access & configure your vario. **Important:** always run only one program at a time!

14.1.1 DIGIFLY AIRTOOLS SOFTWARE (PC / Mac)

- The Digifly “AirTools” software is also available for both Windows and Mac, to download for free at www.digifly.com.
 - It allows the full management of: flights, routes, waypoint, settings, the help language of the “SETUP PARAMETERS”, the complete personalization of the vario’s acoustic profile, airspaces and creating worldwide digital topographic maps, and saving them in your computer to then copy or save them to your microSD card, which will go in your AIR.
 - Connect the Digifly AIR to the PC/Mac with a USB cable and turn both of them on.
 - Press  (“MENU” function) on the instrument, then select "AirTools" using the ,  arrows and press the  button. If the Bluetooth is active, it will prompt you to choose a connection mode; press the  button for USB.
- N.B.** Digifly AirTools program only works via USB cable.
- N.B.** ensure that the **ADVANCED SETUP \ n. 30 A-ID** parameter is set to “**1**”
- On your PC/Mac run the Digifly AirTools program. **Remember** to select “AUTOSEARCH” under “SET COM” in case you are not sure which port your Digifly AIR is using.

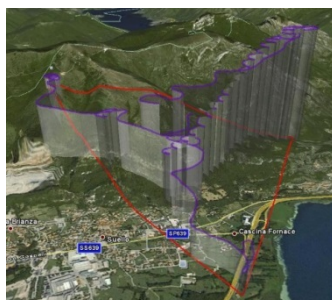
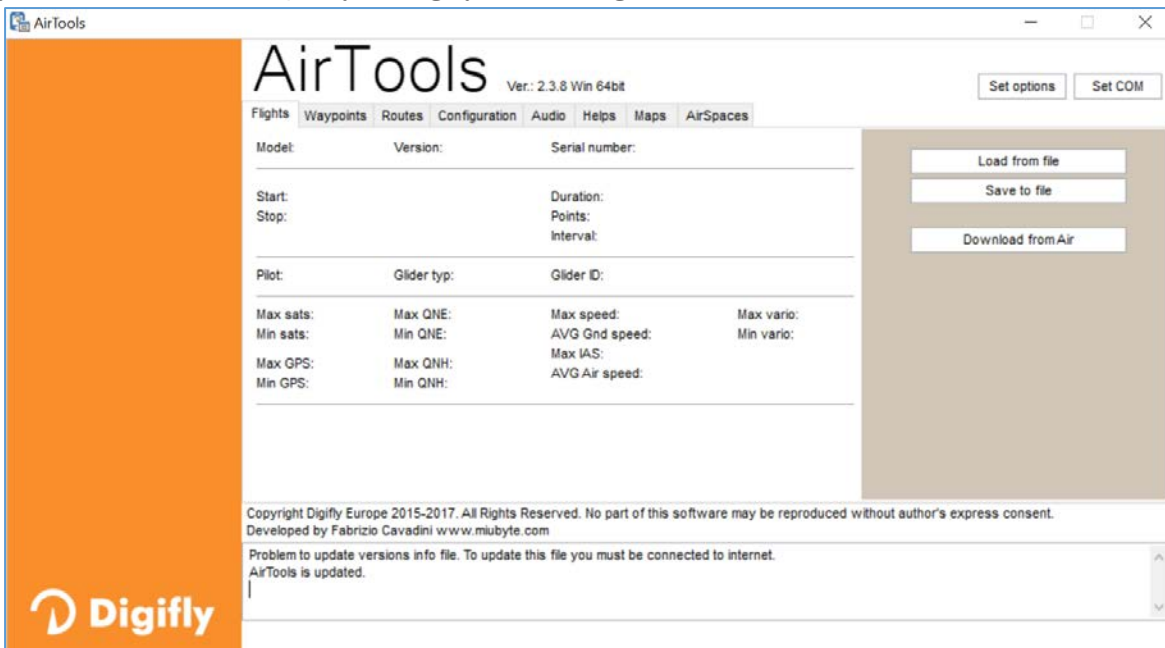

14.1.2 DIGIFLY AIRPAGES SOFTWARE (PC / Mac)

- The Digifly “AirPages” software is available for both Windows and Mac, to download for free at www.digifly.com. It gives you the possibility to create and graphically configure the “User Pages”, so that you can then upload them to the 12 configurable pages of the AIR instrument (GPS Info page is not configurable).

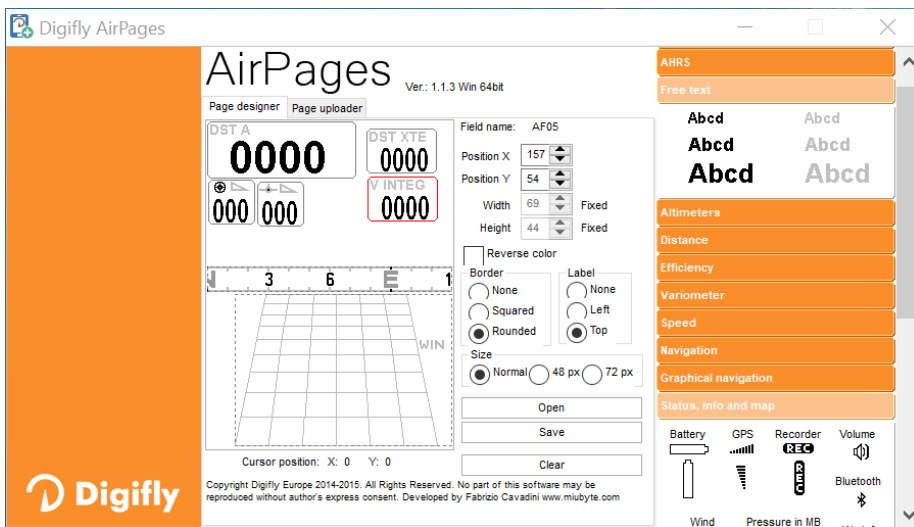
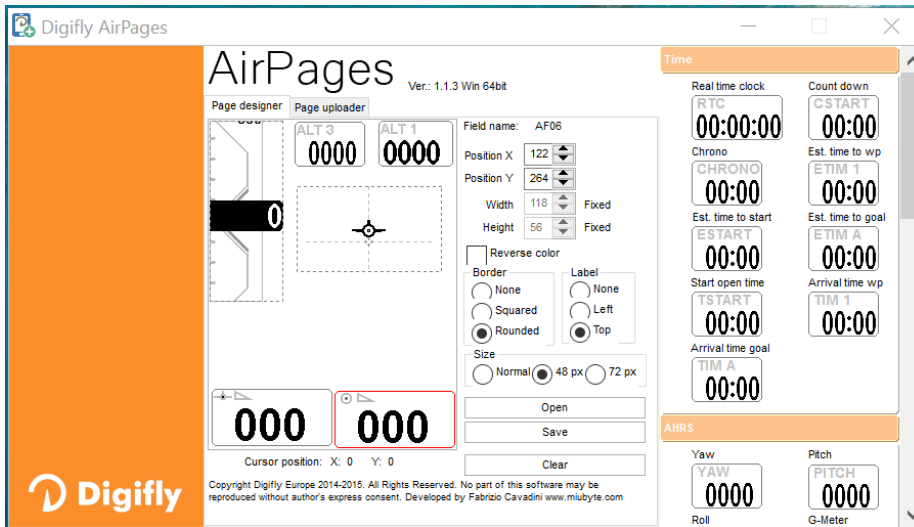

- Connect the Digifly AIR to the PC/Mac with a USB cable and turn both of them on.
- Press **M** (“MENU” function) on the instrument, then select "AirTools" using the **↓**, **↑** arrows and press the **OK** button. If the Bluetooth is active, it will prompt you to choose a connection mode; press the **OK** button for USB.
N.B. Digifly AirPages program only works via USB cable.
N.B. ensure that the **ADVANCED SETUP \ n. 30 A-ID** parameter is set to "1"
- On your PC/Mac run Digifly AirPages.
- It is possible to start creating your own User pages from a blank page or using one of the *.dat files available. Click "Open" and choose a *.dat file

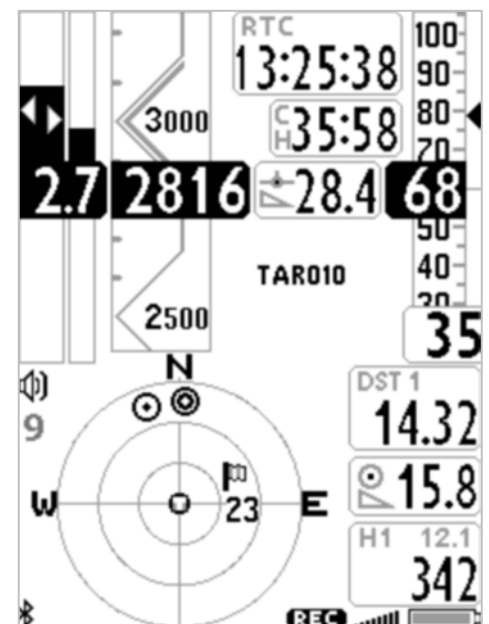

- Drag and release the desired instruments on the workspace.
- To cancel an element from workspace, right click on it and select “delete”.
- To upload your page to the instrument, click on "Page uploader", click on "Set page", select the configurable page of your instrument to which you want to upload your User page (i.e. "Page 8"), click "Start" and wait until the upload is complete; **remember** to select “AUTOSEARCH” under “SET COM” in case you are not sure which port your Digifly AIR is using.
- On the AIR instrument, set the “USR” value for the corresponding page that has been uploaded (in our example, Page 8, so the parameter is **MAIN SETUP \ n. 22 PG8**).
- Your Digifly AIR comes with twelve (12) customizable pages; **each** one of them is linked to one of the twelve (12) configurable parameters (**MAIN SETUP\ n. 15 to 26 - PG1 to 12**) and for **each** page it is possible to configure a different layout:

OFF = the layout view of the page is disabled (the page will be skipped)

STD = it will show the corresponding layout of the preset page by Digifly (pgs. 1 - 12) that come with your AIR.

USR = it will show the corresponding layout of the page "USER PAGE 1 to 12" created and uploaded by the User with the FREE Digifly **AirPages** program.

▪ REFERENCE TO NAME AND CONTENT OF CUSTOMIZABLE PAGES

- PG01 page_1_IntelliComp_flight_thermal **OFF**/STD/USR
- PG02 page_2_IntelliComp_flight_glide **OFF**/STD/USR
- PG03 page_3_IntelliComp_start_thermal **OFF**/STD/USR
- PG04 page_4_IntelliComp_start_glide **OFF**/STD/USR
- PG05 page_5 **OFF**/USR
- PG06 page_6 **OFF**/USR
- PG07 page_7_IntelliXc_cross_thermal OFF/**STD**/USR
- PG08 **page_8_IntelliXc_cross_glide** OFF/**STD**/USR
- PG09 page_9_compass OFF/**STD**/USR
- PG10 page_10_relax OFF/**STD**/USR
- PG11 page_11 glide computer OFF/**STD**/USR
- PG12 page_12_map OFF/**STD**/USR

Default page settings (in bold type) : PG1=OFF, PG2=OFF, PG3=OFF, PG4=OFF, PG5=OFF, PG6=OFF, PG7=STD, PG8=STD, PG9=STD, PG10=STD, PG11=STD, PG12=STD

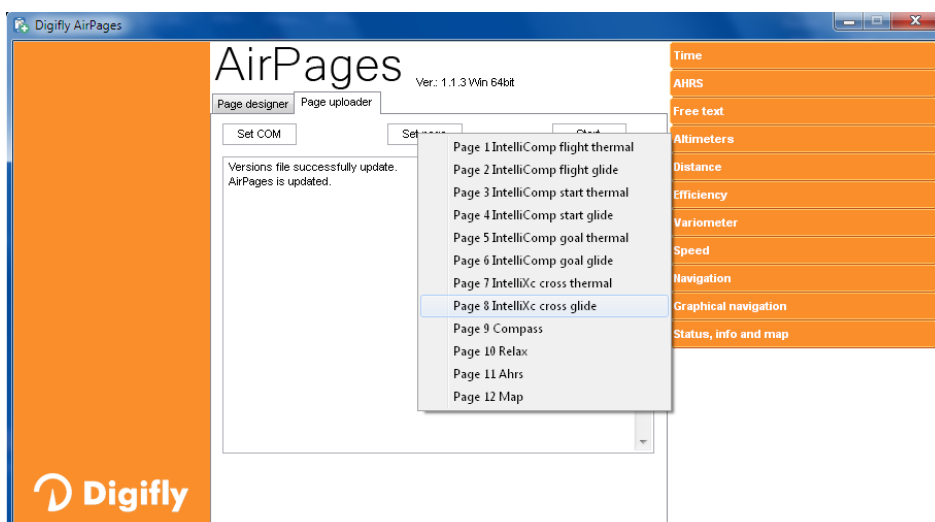

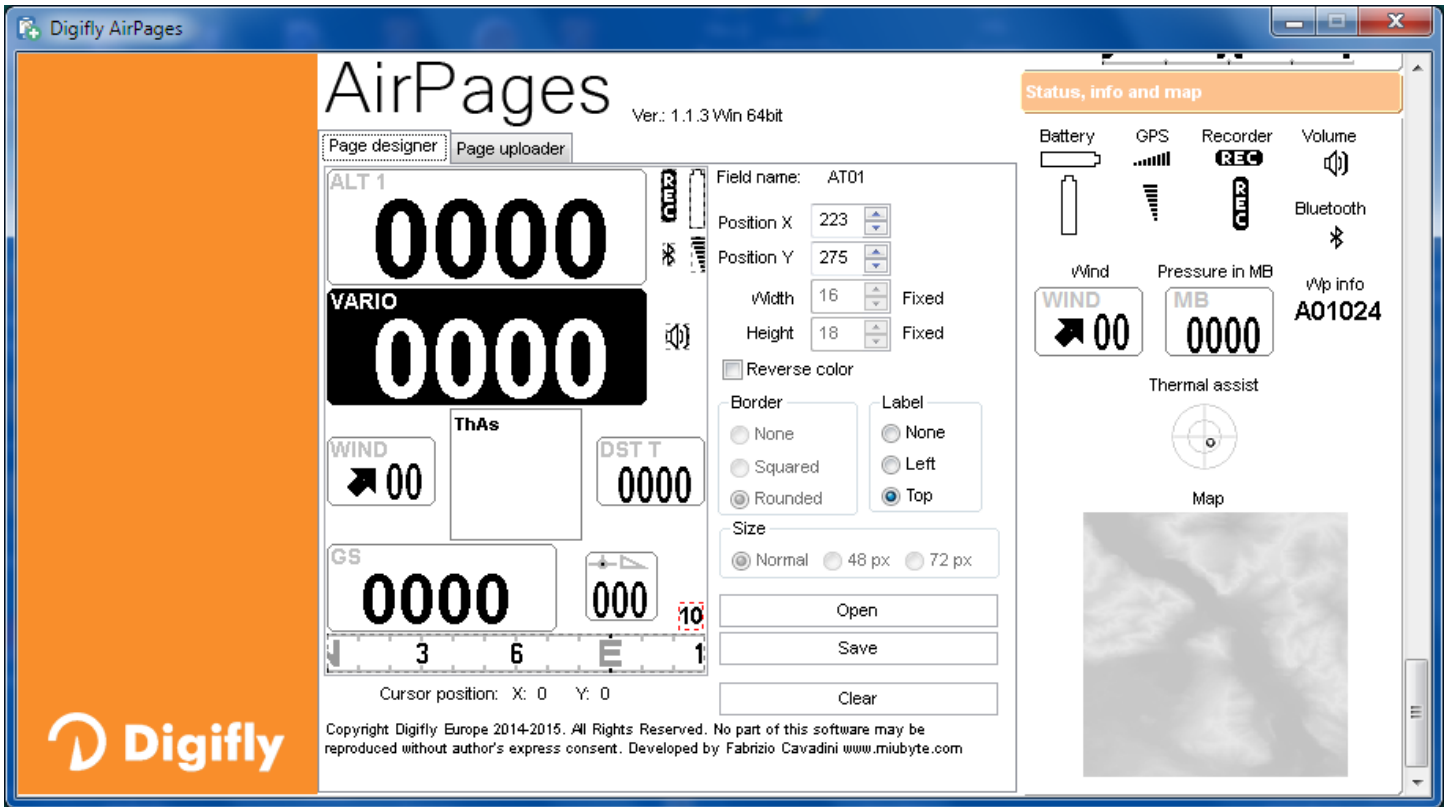





14.1.3 GPSDUMP SOFTWARE (PC, Mac, ANDROID)

- GpsDump is the most commonly used free software among the free flight organizations to manage competitions; it integrates the Digifly protocol.
- GpsDump allows you to download your tracklogs and upload/download waypoints to and from your USER and COMPETITION waypoint banks.
- **GpsDump for PC/MAC :**

These GpsDump versions will only communicate with your Digifly AIR only via the USB cable and do require the installation of the FTDI USB drivers (see paragraph 13.1).

How to use GPSDump:

- Press the  button (“MENU” function), scroll down to "AirTools" using the  and  buttons then press . If your Bluetooth is turned on, you will need to choose between communication via USB cable or Bluetooth, in this case, press  for USB cable.



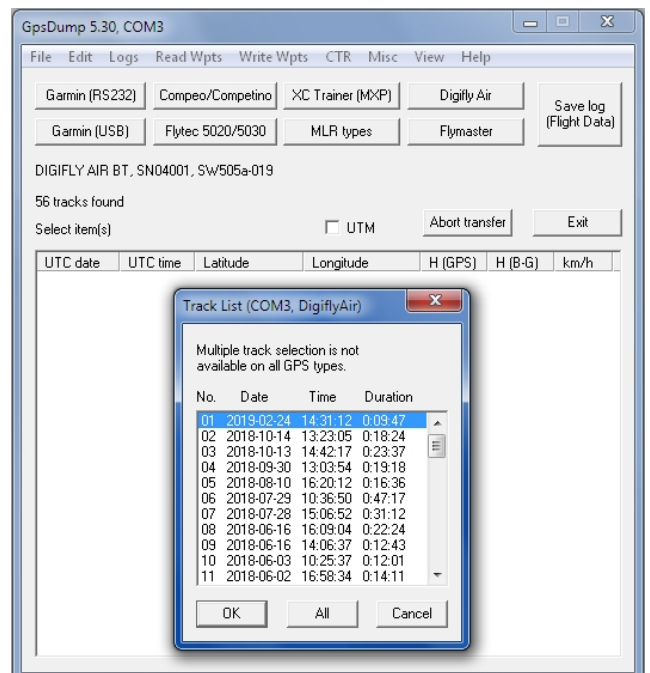
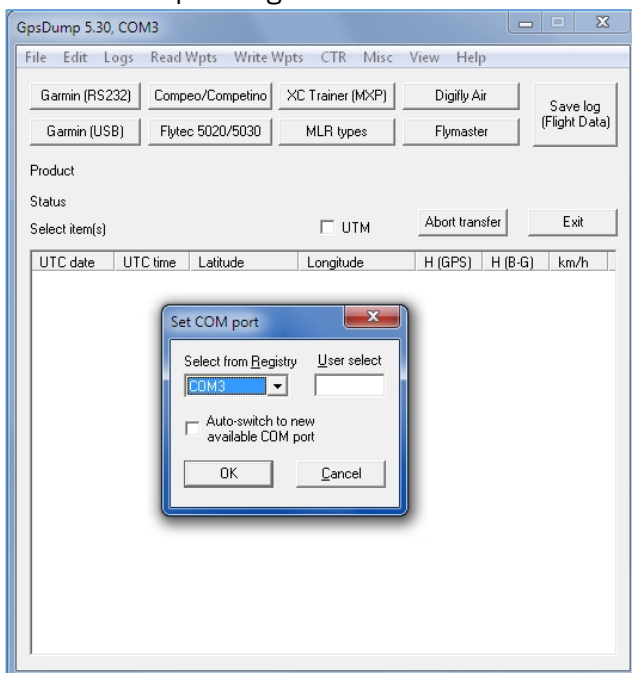

N.B. ensure that the **ADVANCED SETUP \ n. 30 A-ID** parameter is set to **"1 "**

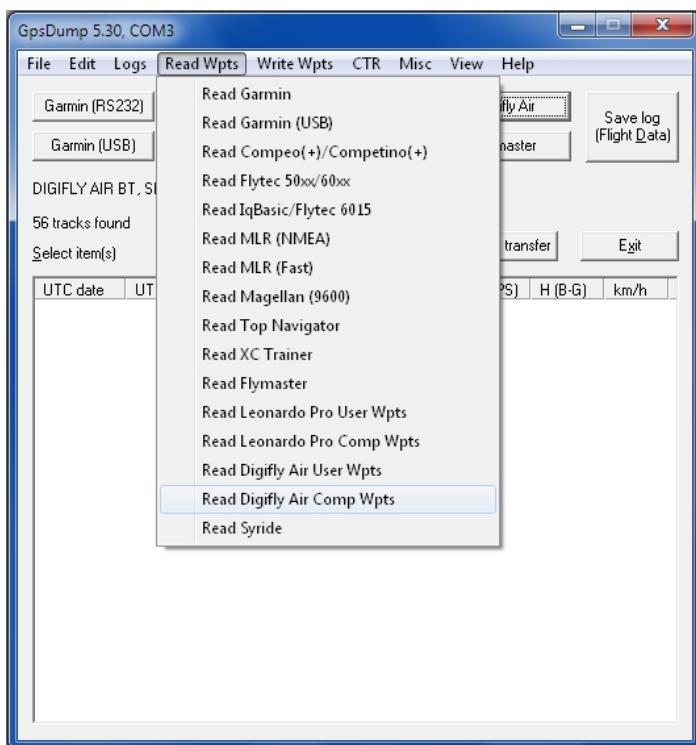
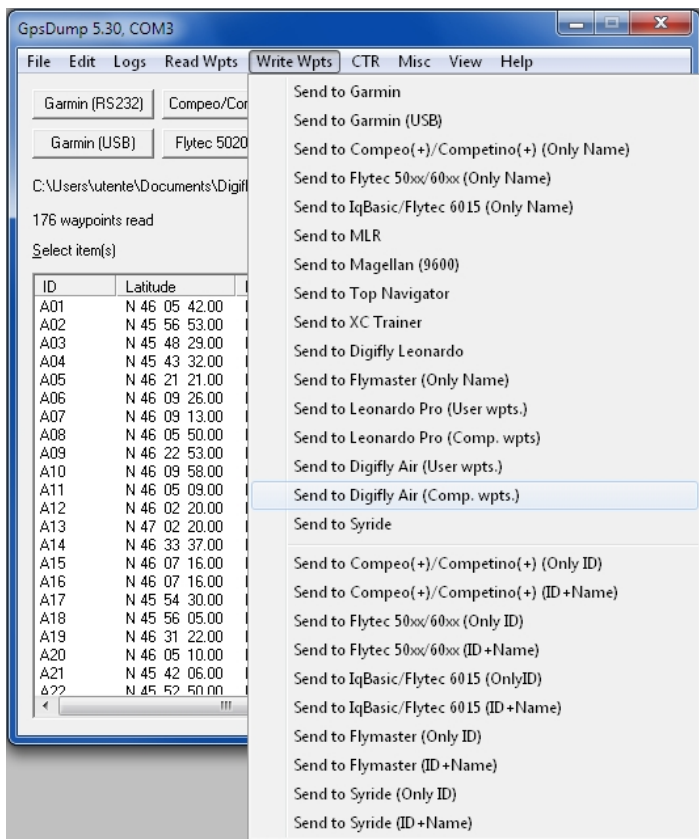
- Open your GPSDump and select the COM Port: go to the MISC tab then Set COM Port
- **To download a tracklog from your instrument:** click on the “Digifly Air” button on the GPSDump window then select the flight you want to download from the list that pops up.
- **To upload waypoints to your AIR’s Competition waypoint bank:** go to menu “File / Open wpts”, open the waypoint file from your computer, select the waypoints you want to upload, go to Menu / “Write Wpts” then select “Send to Digifly Air Comp wpts”
- **To upload waypoints to your AIR’s User waypoint bank:** go to menu “File / Open wpts”, open the waypoint file from your computer, select the waypoints you want to upload, go to Menu / “Write Wpts” then select “Send to Digifly Air User wpts”
- **To download waypoints from your AIR’s Competition waypoint bank:** go to Menu / “Read Wpts” then “Read Digifly Air Comp wpts”
- **To download waypoints from your AIR’s User waypoint bank:** go to Menu / “Read Wpts” then “Read Digifly Air User wpts”
- See example images below.









■ GpsDump for Android via USB cable:

- Connect the AIR to the Smartphone using a USB cable and a USB-OTG (On-The-Go) adapter; driver installation is not required.
- On your instrument, press the  button (“MENU” function), use the  and  to scroll down to "AirTools" and press  to enter. If your Bluetooth is turned on, you will need to choose between communication via USB cable or Bluetooth, in this case, press  for USB cable.

N.B. ensure that the **ADVANCED SETUP \ n. 30 A-ID** parameter is set to **"1 "**

- **Note:** when communicating via USB cable, it is important to select **"Digifly Air"** every time you are required to choose a GPS from the "Select GPS type" list.
 - **To download a tracklog from your AIR:** click on the "TRK" tab, then on "READ" and select "Digifly Air" from the "Select GPS type" list. From the flight list, click on the one you want to download and save it in IGC format. If applicable, you can then send it directly to the XCContest server.
 - **To upload waypoints to your AIR:** click on the "WPT" tab, then read file waypoint and select all the waypoints you want to upload, click on write GPS" and select "Digifly Air" from the "Select GPS type" list, finally choose the "wpt user" or "wpt competition" bank to store the waypoints.
 - **To download waypoints from your instrument:** click on the "WPT" tab, then read GPS, select "Digifly Air" from the "Select GPS type" list, choose "wpt user" or "wpt competition" and then click on "write waypoint" on file.
- #### ■ GpsDump for Android via Bluetooth SPP :
- Ensure that the **ADVANCED SETUP \ n. 29 ACHA** parameter is set to **"SPP "**, ensure that the **ADVANCED SETUP \ n. 30 A-ID** parameter is set to **"1 "** and to have already paired your Android device to your Digifly AIR (see paragraph 13.2.1).

- Press the  button (“MENU” function) on your AIR and scroll down to "AirTools" using the  and  buttons, then press  to enter. You will be prompted to choose between communication via USB Cable or Bluetooth, press the  button (via Bluetooth).
- **Note:** when using Bluetooth communication, it is important to make sure to select “Bluetooth devices” (last item on list) from the “Select GPS type” list and then select your instrument by clicking on “Digify AirXXX” where “XXX” are the last 3 digits of your AIR’s serial number; for example, "Digify Air123"
- **To download a tracklog from your instrument:** click on “TRK” then on ”READ”, select “Bluetooth Devices” from the “Select GPS type” list then from “Bluetooth devices” and click on your “Digify AirXXX”. From the list, click on the flight you want to download and save it in IGC format; if applicable, you can send it directly to the XCContest server.
- **To upload waypoints to your AIR:** click on “WPT” then on read file waypoint, select all the waypoints you want to upload, then click on “write GPS”, select “Bluetooth devices” from the “Select GPS type” list and click on your “Digify AirXXX” from the “Select BT device” options and then choose the “wpt user” or “wpt competition” bank to store the waypoints.
- **To download waypoints from you AIR:** go to “WPT” then read GPS, select “Bluetooth devices” from the “Select GPS type” list, then go to “Select BT device” and select your “Digify AirXXX”, choose the “wpt user” or “wpt competition” bank and then write waypoint on file.

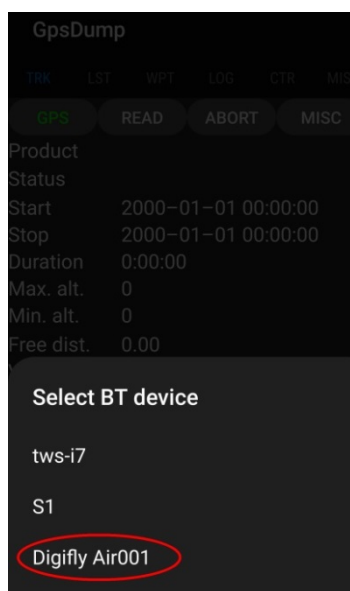
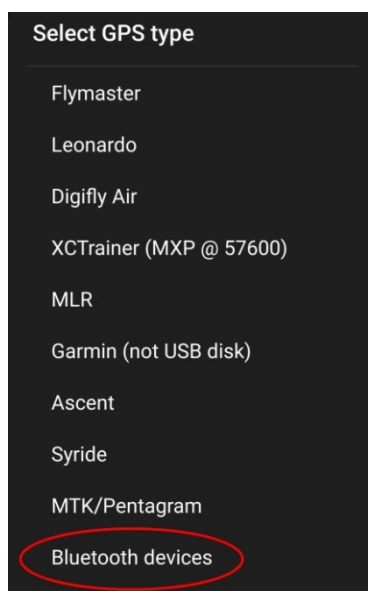
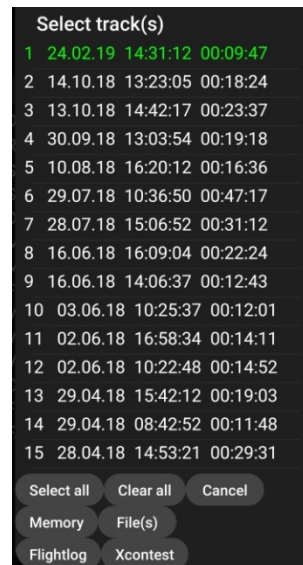
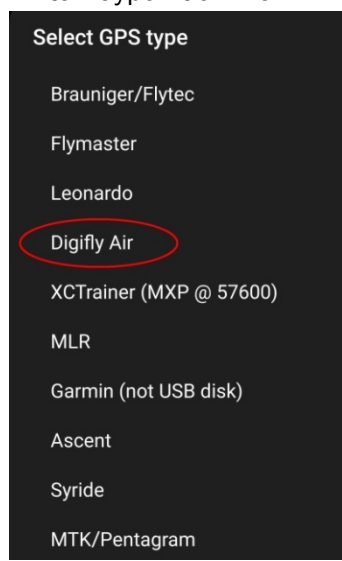
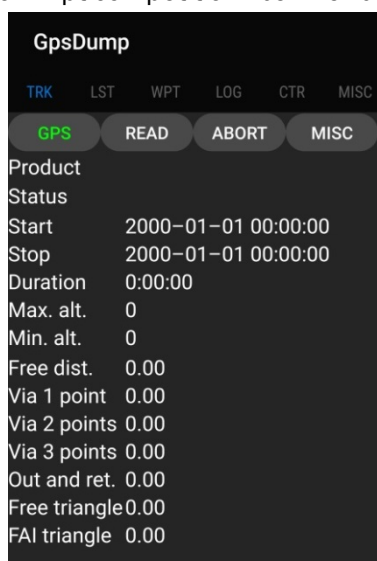

14.2 DIGIFLY AIRUPDATER SOFTWARE FOR FIRMWARE UPDATE (PC, Mac)

- When you buy a Digifly AIR, besides the FREE specialized management software and the possibility of creating FREE worldwide digital topographic maps, you will also get FREE firmware updates for life!
- The firmware on your Digifly instrument can be updated to new versions using the “AirUpdater” program available for Windows and Mac. This free software can be downloaded from our web site



www.digifly.com and allows you to get new functions and improvements on your instrument.

- The firmware update works only with the USB cable. **Note:** it is **not** possible to update the firmware via the Bluetooth connection.

N.B. ensure that the **ADVANCED SETUP \ n. 30 A-ID** parameter is set to **”1 “**



14.2.1 FIRMWARE UPDATE PROCEDURE

- **Very important!** Before the firmware update, make sure you have the correct FTDI driver installed and verify that the instrument and your computer communicate correctly via USB: for example, run AirTools and download the “Help UK” file from your AIR or any similar operation.

1) Make sure that your instrument’s battery is fully charged. It is important!

2) Close all other PC/Mac programs that are running, including the antivirus & firewall.

3) Make sure that the instrument is turned off and connected with the USB cable to your computer.

4) Press and hold the  key first and hold it down, then simultaneously press and hold the  key and wait until the instrument emits a long acoustic “beep”. Now the instrument is turned on and is in “boot loader mode”, waiting for the firmware upload. **Note:** the screen will be totally blank at this point.

5) First release the  key and then the  key.

6) On your PC/Mac run the Digifly’s firmware updating program "AirUpdater".

7) Set the COM Port (“Auto-search”) and the speed (115200) should be automatically set, press the “Start” button, then select the firmware file (e.g. Air704a_BT_Gr_19.hex) and confirm.

Note: If you need to upload the same firmware version: right click on the Start button, click on "Force full firmware update" then select the firmware file and confirm.







8) The complete update procedure takes about 10 minutes; once finished, your computer will provide an acoustic and visible message, then the Air instrument will switch off automatically.

- **Important!** If you are unable to update the firmware due to lack of communication, the firmware will still be in the instrument, so forcing the AIR to exit from bootloader mode should be enough. This is done by resetting the instrument:

Press the  and  buttons at the same time for more than 5 seconds; this will force the instrument to turn

off and resets it. Turn the instrument back on as usual. This will **not** erase any data or settings from your instrument.

On the other hand, if the update is underway and stops halfway through, then the firmware has been erased; even though the instrument is completely fine, there is **NO DAMAGE**, but it will drain the battery fairly quickly. To restore it, you will need to do a different kind of reset using 3 buttons that will reset the AIR and, at the same time, bring it to bootloader mode:

- Press and hold the 3   and  keys together.
- Wait 5 seconds and then release the  key; the instrument emits a long acoustic “beep”.
- First release the  key and then the  key. Now the instrument is turned on and it is in “boot loader mode”, waiting for the firmware upload. **Note:** the screen will be totally blank at this point.
- Resume from step 6) making sure the “Set COM” is on “Auto-search” and “Set speed” on “115200”.

14.3 FLIGHT PLAYBACK SIMULATOR COMPATIBLE WITH CONDOR SIMULATOR

- The flight playback simulator accepts inbound RMC, GGA and LXWPO strings sent from the Condor simulator. To activate the playback simulator, use the **VARIOMETER SETUP \ n. 18 SIMV** parameter :
SIMV = 0: simulation mode disabled (default)
SIMV = 1: acoustic vario simulation enabled
SIMV = 2: standard playback simulation mode enabled using a USB cable at 115200 baud, it will accept inbound RMC, GGA and PDGFTL1 strings
SIMV = 3: Condor playback mode enabled using a USB cable at 115200 baud, it will accept inbound RMC, GGA, PDGFTL1 and LXWPO strings
SIMV = 4 : Condor playback mode enabled using a USB cable at 4800 baud it will accept inbound RMC, GGA, PDGFTL1 and LXWPO strings

Note: the flight playback simulation ONLY receives the strings with GPS data and Airdata via a USB cable connection.

Note: the date is missing on the RMC strings sent by the Condor simulator; therefore, the date (19/8/2020) will be automatically added to these incoming strings.

15 LIVE TELEMETRY with the integrated Digi-FLYBOX

- The Digifly AIR integrates the **Digi-FLYBOX** which is a real-time Telemeter:
with this fantastic feature, the AIR sends its Telemetry (all the information from its high quality sensors), in real time at a continuous high speed of 10 times per second via USB cable or Bluetooth, to external devices such as E-Reader, Smartphone, Tablet, etc. that have a software compatible to receive, decode and display the Digifly's Telemetry such as LK8000, XCSoar, XCTrack, Top Hat, GpsDump, TTLiveTrack24, Flyskyhy (see paragraphs 15.2, 15.3, 15.4, 15.5, 15.6, 15.7, 15.8 for more details about these programs).
The **Digi-FLYBOX** is one of those characteristics of your AIR that marks that difference among flight instruments, making it unique and unbeatable when it comes to Quality/Features/Price!
- This information (Telemetry) can also be used to **live track** to any server using, for example, GPSDump (see 15.6) or TTLiveTrack24 (see 15.7) on an Android Smartphone or Flyskyhy (see 15.8) on an Iphone.
- The most important data sent by the real-time telemetry is :
Barometric Altimeters, GPS Altitude, GPS Ground Speed, IAS/TAS Air speed (Pitot Tube), Variometer assisted by the synthetic Inertial Platform, GPS Position, etc.

15.1 ACTIVATING THE DIGIFLY'S TELEMETRY DATA OUTPUT Digi-FLYBOX

- To activate the Digifly's telemetry data output you have to:
 - Select the telemetry GPS data transmission with the **ADVANCED SETUP \ n. 23 TGPS** parameter "Enable Telemetry GPS Output" used to select the telemetry GPS data transmission mode:
0 (default) = no transmission of GPS data, 1 = transmits GPS data once per second
 - Select the type of protocol used to transmit the "AirData" information with the **ADVANCED SETUP \ n. 24 TAIR** parameter.
 - Select the frequency in which the "AirData" information is transmitted with the **ADVANCED SETUP \ n. 25 TFRQ** parameter
 - Select USB cable or Bluetooth mode with the **ADVANCED SETUP \ n. 26 TCHA** parameter "Telemetry communication channel" : OFF (default), USB, SPP or BLE.
If **TCHA = USB**, the Telemetry will always automatically be sent via USB cable, only.
If **TCHA = SPP or BLE**, the Telemetry will be transmitted via Bluetooth and it can be sent either automatically (**TAUT = ON**) or it can be sent manually using the "Start Telemetry BT" feature on the Menu. This last parameter, will prompt you to choose one of the following options:
"Press (UP) to clear pair" will delete any previous pairings
"Press (DOWN) to link BT" will send the Telemetry via Bluetooth
"Press (Menu) to exit" will take you back to the Main Menu page
 - Set the **ADVANCED SETUP \ n. 27 TAUT** parameter "Telemetry BT Auto Connection" :
OFF(default) = Telemetry transmission requires a manual start from the Main Menu using the "Start Telemetry BT" parameter, ON = autoreconnect feature enabled
 - Set the **ADVANCED SETUP \ n. 28 T-ID** parameter "Telemetry BT ID" :
1(default) = ID will be Digifly, 2 = ID will be Bluefly

To set these parameters correctly, follow the instructions found in the corresponding sections that talk about the different software compatible with the Digifly's Telemetry:

- **LK8000** (see paragraph 15.2)
- **XCSoar** (see paragraph 15.3)
- **XCTrack** (see paragraph 15.4)
- **Top Hat** (see paragraph 15.5)
- **GpsDump** (see paragraph 15.6)
- **TTLiveTrack24** (see paragraph 15.7)
- **Flyskyhy** (see paragraph 15.8)

15.1.1 Digi-FLYBOX TELEMETRY GPS DATA SELECTION

- Select the telemetry GPS data transmission with the **ADVANCED SETUP \ n. 23 TGPS** parameter:
 - TGPS=0 : no GPS data transmitted (default).
 - TGPS=1 : GPS data (\$GPGGA + \$GPRMC) sent once per second

- DATA COMMUNICATION SETTINGS: **115200 bauds**, no parity, 8 data bit, 1 stop bit
- The Nmea field “checksum” is composed by "*" and 2 hex digits representing the "exclusive OR”

\$GPRMC,112426.000,A,4429.6564,N,01120.8056,E,0.62,15.74,271218,,,A*53<CR><LF>

Name	Example	Units	Description
Message ID	\$GPRMC		RMC protocol header
UTC Time	112426.000	hhmmss.sss	
Status	A		A=data valid or V=data not valid
Latitude	4429.6564	ddmm.mmmm	
N/S indicator	N		N=north or S=south
Longitude	01120.8056	dddmm.mmmm	
E/W indicator	E		E=east or W=west
Speed Over Ground	0.62	knots	
Course Over Ground	15.74	degrees	True
Date	271218	ddmmyy	
Magnetic Variation degrees		degrees	(not used)
Magnetic Variation E/W			E=east or W=west (not used)
Mode indicator	A		N=data not valid, A=Autonomous, D=Differential, E=Estimated
Checksum	*53		Nmea checksum
<CR><LF>			End of message termination

\$GPGGA,112426.000,4429.6564,N,01120.8056,E,1,6,1.37,58.9,M,47.6,M,,*6F<CR><LF>

Name	Example	Units	Description
Message ID	\$GPGGA		GGA protocol header
UTC Time	112426.000	hhmmss.sss	
Latitude	4429.6564	ddmm.mmmm	
N/S indicator	N		N=north or S=south
Longitude	01120.8056	dddmm.mmmm	
E/W indicator	E		E=east or W=west
Position Fix Indicator	1		0=fix not available, 1=GPS fix, 2=Differential GPS fix
Satellites Used	6	Range 0 to 14	Number of satellites used in position fix
HDOP	1.37		Horizontal Dilution of Precision
MSL Altitude	58.9	meters	mean-sea-level Altitude (geoid)
Units of MSL Altitude	M	meters	
Geoidal Separation	47.6	meters	Difference between the WGS-84 reference ellipsoid surface and the mean-sea-level altitude (geoid)
Units of Geoidal Separation	M	meters	
Age of Differential Correction		second	Null field when DGPS is not used
Differential Ref. Station ID			Null field when DGPS is not used
Checksum	*6F		Nmea checksum
<CR><LF>			End of message termination

15.1.2 Digi-FLYBOX TELEMETRY AIRDATA TYPE SELECTION

- The **ADVANCED SETUP \ n. 24 TAIR** parameter defines the type of protocol used to transmit the "AirData" information (default=DGF):
 - **DGF** "\$PDGFTL1, QNE m, QNH m, vario cm/s, netto vario , IAS km/h, L/D ground tens, wind speed km/h , wind dir, volt battery hundreds, *chksum[CR][LF]"
 - **LK8** "\$LK8EX1,,altitude QNE m,vario cm/s,,volt battery hundreds*checksum[CR][LF]"
 - **LXW** "\$LXWPO,,IAS(km/h),baroaltitude QNH(m),vario(m/s),,,,,,,*checksum[CR][LF]"
 - **_PR** "_PRS 17AB4[CR][LF]" barometer in hundreds of mb in 5-digit hex (Flynet _PRS protocol)
 - **PRS** "PRS 17AAD[CR][LF]" barometer in hundreds of mb in 5-digit hex (BlueFly PRS protocol)
 - **BF5** "\$BFV,pressure(Pa),vario(cm/s),,,*checksum[CR][LF]" (BlueFly BFV5 protocol)
 - **BF6** "\$BFV,pressure(Pa),vario(cm/s),,,volts(V)*checksum[CR][LF]" (BlueFly BFV6 protocol)

- **DATA COMMUNICATION SETTINGS: 115200 bauds**, no parity, 8 data bit, 1 stop bit
- The Nmea field "checksum" is composed by "*" and 2 hex digits representing the "exclusive OR"

\$PDGFTL1,2025,2000,250,-14,45,134,28,65,382,153*14<CR><LF>

Name	Example	Units	Description
Baro Altitude QNE(1013.25)	2025	meters	2025 mt (range -300 ... +9160)
Baro Altitude QNH	2000	meters	2000 mt (range -300 ... +9160)
Vario	250	cm/sec	+2,50 m/s (range -25,00 ... +25,00)
Netto Vario	-14	dm/sec	-1,40 m/s (range -25,00 ... +25,00)
Indicated / True Air Speed	45	km/h	45 km/h (range 0 ... 140)
Ground Efficiency	134	ratio	13,4 : 1 (range 0,0 ... 99,9)
Wind Speed	28	km/h	28 km/h (range 0 ... 140)
Wind Direction	65	degrees	65 degrees (range 0 ... 359)
Main Lithium Battery Voltage	382	0.01 volts	3,82 volts (range 0,00 ... 4,20)
Backup AA Battery Voltage	153	0.01 volts	1,53 volts (range 0,00 ... 1,60)
Checksum	*14		Nmea checksum
<CR><LF>			End of message termination

15.1.3 Digi-FLYBOX TELEMETRY AIRDATA FREQUENCY SELECTION

- The **ADVANCED SETUP \ n. 25 TFRQ** parameter defines the frequency in which the "AirData" information is transmitted:
 - TFRQ = 0 (default) : no AirData is transmitted
 - TFRQ = from 1 to 10 : transmits AirData from 1 to 10 times per second.

15.2 Digi-FLYBOX TELEMETRY TO LK8000

- The free **LK8000** software running on an external device (e.g. E-Reader, Smartphone, Tablet, etc.) receives, decodes and displays the **Digi-FLYBox Telemetry Data** sent in real time at high speed by the AIR via **USB OTG cable** or **Bluetooth**.

- **How to use telemetry communication via USB-OTG cable:**

- On your AIR, do a one-time setting of the following parameters:

ADVANCED SETUP \ n. 23 TGPS = 1

ADVANCED SETUP \ n. 24 TAIR = DGF

ADVANCED SETUP \ n. 25 TFRQ = 3

ADVANCED SETUP \ n. 26 TCHA = USB

ADVANCED SETUP \ n. 27 TAUT = OFF

ADVANCED SETUP \ n. 28 T-ID = 1

- To correctly decode the Digifly's telemetry, it is necessary (only once) to enter in the LK8000 : FLY mode, Menu, Config 2/3, LK8000 Setup,

Device Setup, Device A : Name: **Digifly**, Port: **USB:0403:6015**, Baudrate: 115200 [8bit], Serial mode: Normal, Device Model: Generic. Exit configuration

- The data will be continuously transmitted, except when you are in the Menu pages
- **Note:** use a USB OTG adapter and verify that the external device (e.g. Smartphone) also provides power supply through the USB cable; otherwise, it will be necessary to use a USB-OTG Y cable to provide 5V external power using, for example, a battery pack.

No drivers are required to use a USB-OTG (On-The-Go) cable.

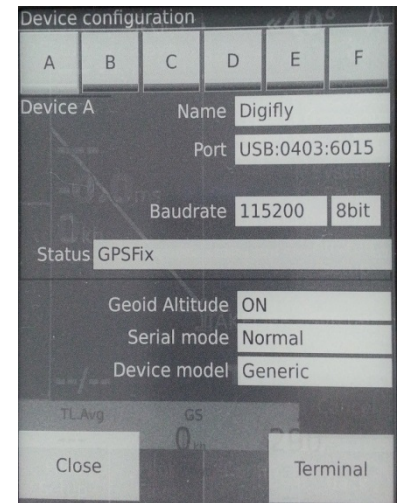

- **How to use telemetry communication via Bluetooth SPP:**

- On your AIR, do a one-time setting of the following parameters:

ADVANCED SETUP \ n. 23 TGPS = 1

ADVANCED SETUP \ n. 24 TAIR = DGF

ADVANCED SETUP \ n. 25 TFRQ = 3

ADVANCED SETUP \ n. 26 TCHA = SPP

ADVANCED SETUP \ n. 27 TAUT = ON

ADVANCED SETUP \ n. 28 T-ID = 1

- In order to use the LK8000 software you must have already previously done (only once) the pairing procedure with the external device (see 13.2.1)

- To correctly decode the Digifly's telemetry, it is necessary (only once) to enter in the LK8000 : FLY mode, Menu, Config 2/3, LK8000 Setup, Device Setup, Device A : Name: **Digifly**, Port: **BT:Digifly Airnnn** (where "nnn" are the last three digits of your instrument's serial number), Serial mode: Normal, Device Model: Generic. Exit configuration

- The steps to follow each time you want to send the telemetry are:

1) On the **AIR**, go to MENU "Telemetry BT".

2) Run the LK8000 software on the external device.

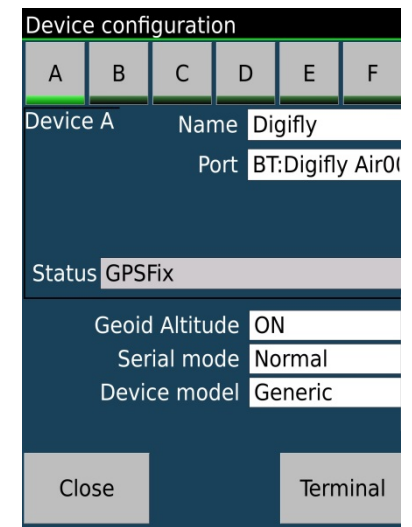

3) When the AIR receives from the confirmation that it is connected the external device, it automatically exits from the "Telemetry BT" menu, returns to the current page of instruments, turns the Bluetooth icon on and activates the continuous transmission of real-time Digifly telemetry data at high speed. In case of problems, press the  key on the AIR to exit and try again.

- If everything is correct, the "Monitor" page in LK8000 will display the telemetry data transmitted from the AIR
- For more info about the LK8000 software please visit their website www.lk8000.it

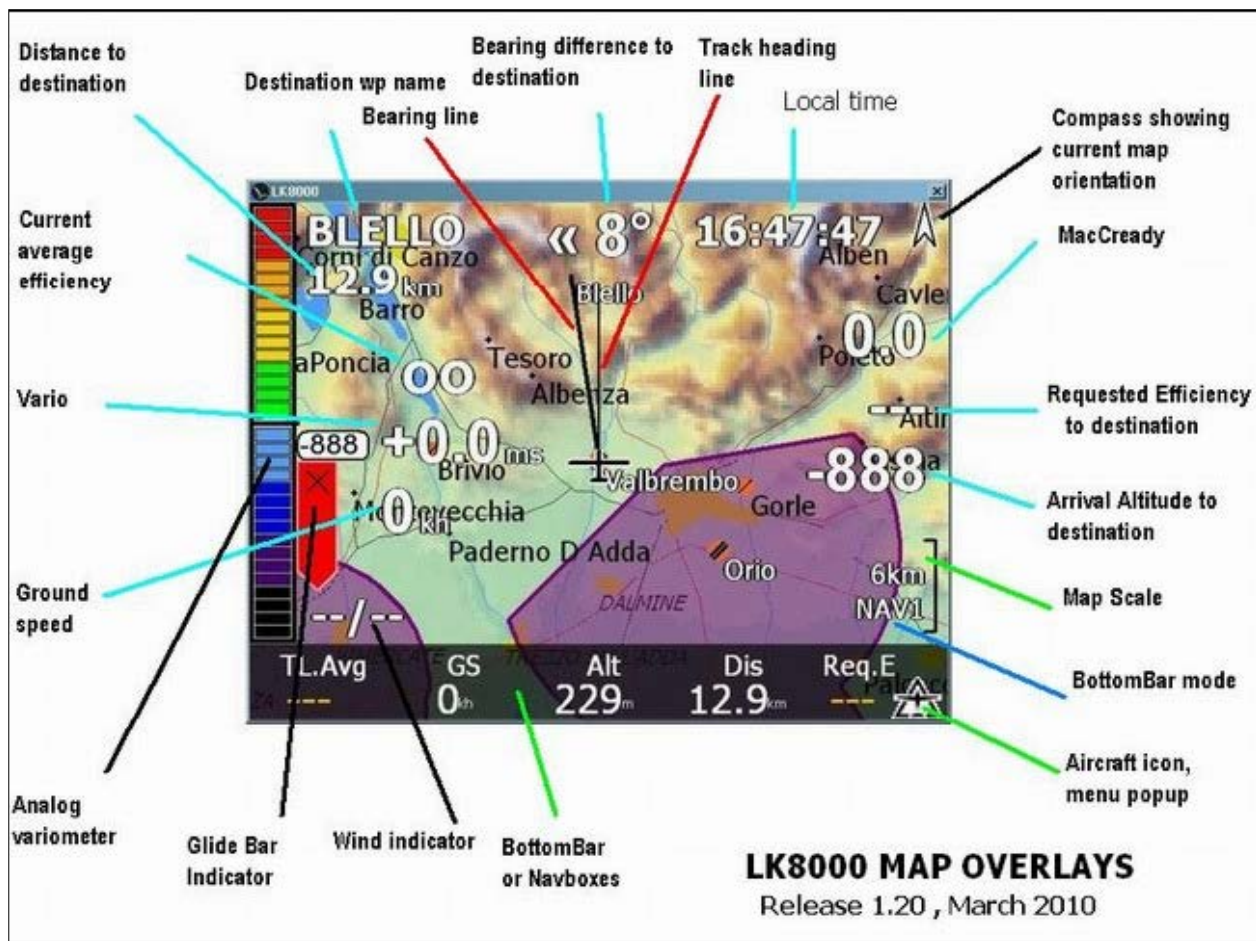

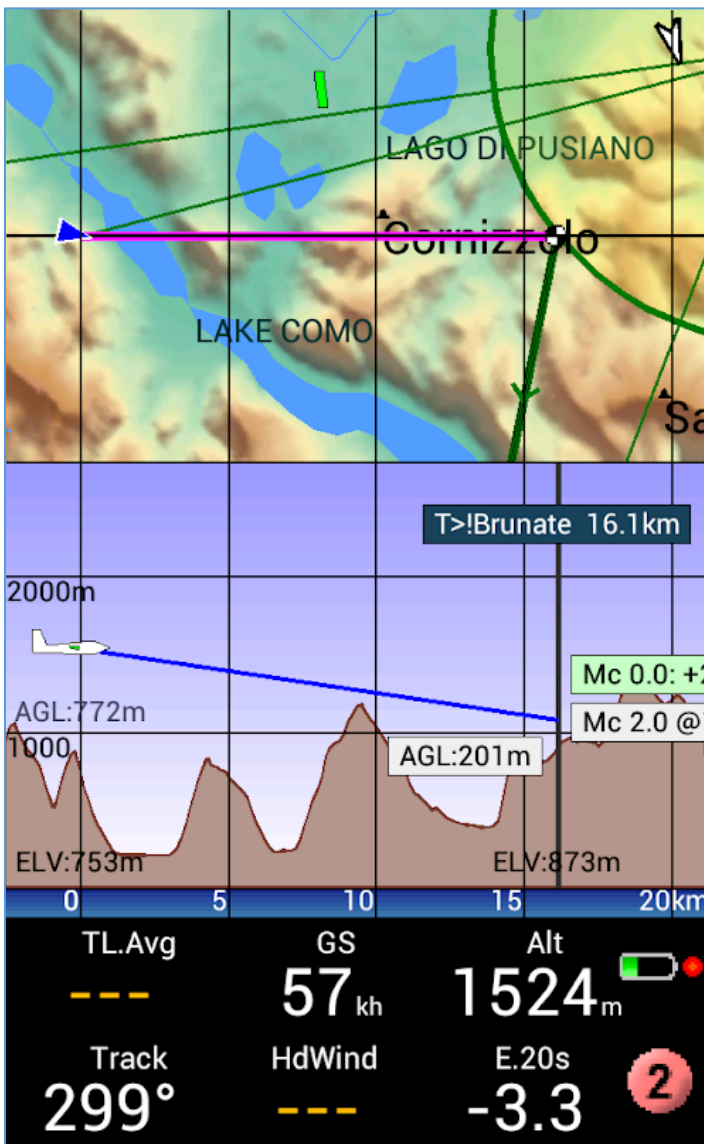

15.3 Digi-FLYBOX TELEMETRY TO XCSOAR

- The free **XCSoar** software running on an external device (e.g. E-Reader, Smartphone, Tablet, etc.) receives, decodes and displays the **Digi-FLYBox Telemetry Data** sent in real time at high speed by the AIR-PRO via **Bluetooth**.

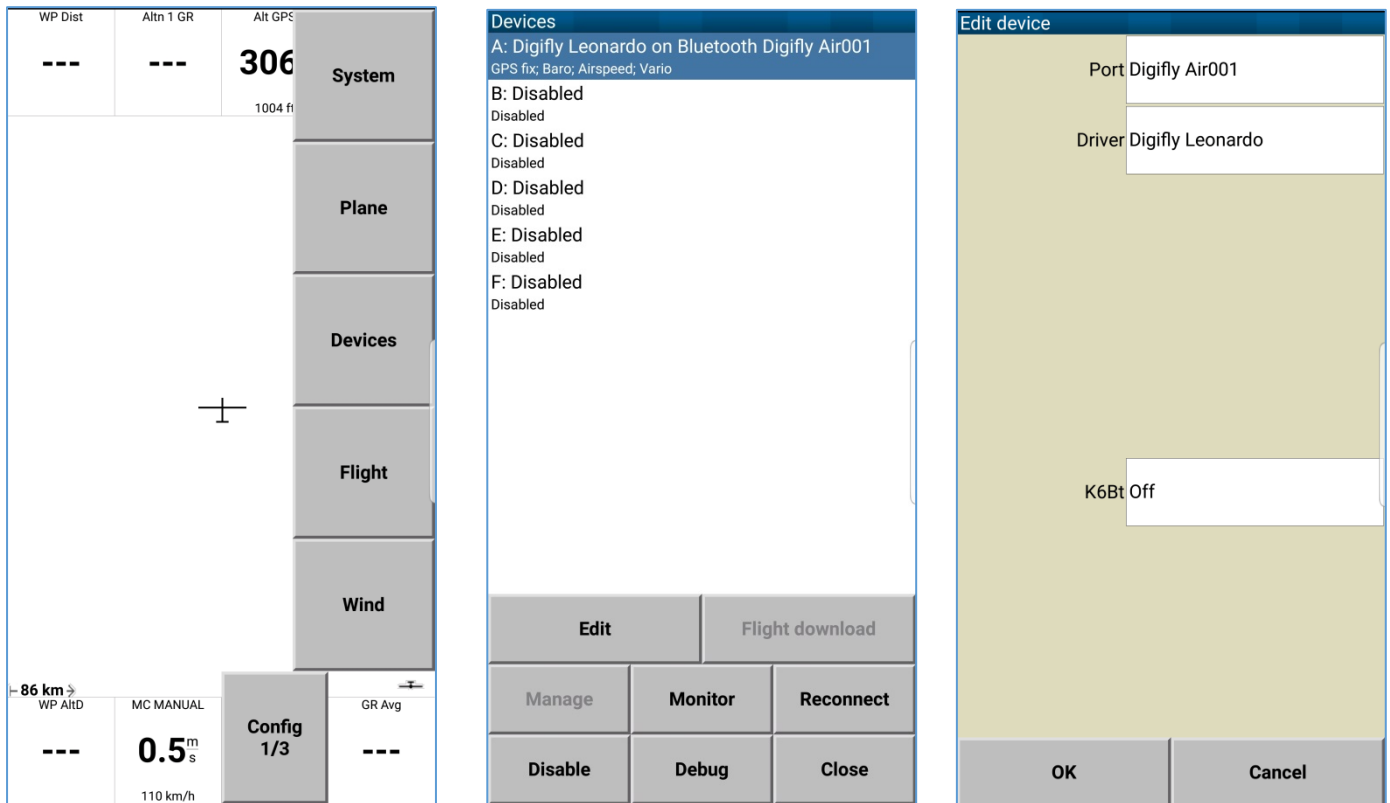

- **How to use telemetry communication via Bluetooth SPP:**

- On your AIR, do a one-time setting of the following parameters:
 - ADVANCED SETUP \ n. 23 TGPS = 1**
 - ADVANCED SETUP \ n. 24 TAIR = DGF**
 - ADVANCED SETUP \ n. 25 TFRQ = 3**
 - ADVANCED SETUP \ n. 26 TCHA = SPP**
 - ADVANCED SETUP \ n. 27 TAUT = ON**
 - ADVANCED SETUP \ n. 28 T-ID = 1**
- In order to use the XCSoar software you must have already previously done (only once) the pairing procedure with the external device (see 13.2.1)
- To correctly decode the Digifly's telemetry, it is necessary (only once) to enter in the XCSoar : FLY mode, Menu, Config 1/3, Devices, Edit Device A : Port: **Digifly Airnnn** (where "nnn" are the last three digits of your instrument's serial number), Driver: **Digifly Leonardo**, Close configuration.
- The steps to follow each time you want to send the telemetry are:
 - 1) On the **AIR**, go to MENU "**Telemetry BT**".
 - 2) Run the XCSoar software on the external device.
 - 3) When the **AIR** receives from the confirmation that it is connected the external device, it automatically exits from the "Telemetry BT" menu, returns to the current page of instruments, turns the Bluetooth icon on and activates the continuous transmission of real-time Digifly telemetry data at high speed. In case of

problems, press the  key on the AIR to exit and try again.

- If everything is correct, the "Monitor" page in XCSoar will display the telemetry data transmitted from the AIR
- For more info about the XCSoar software please visit their website www.xcsoar.org

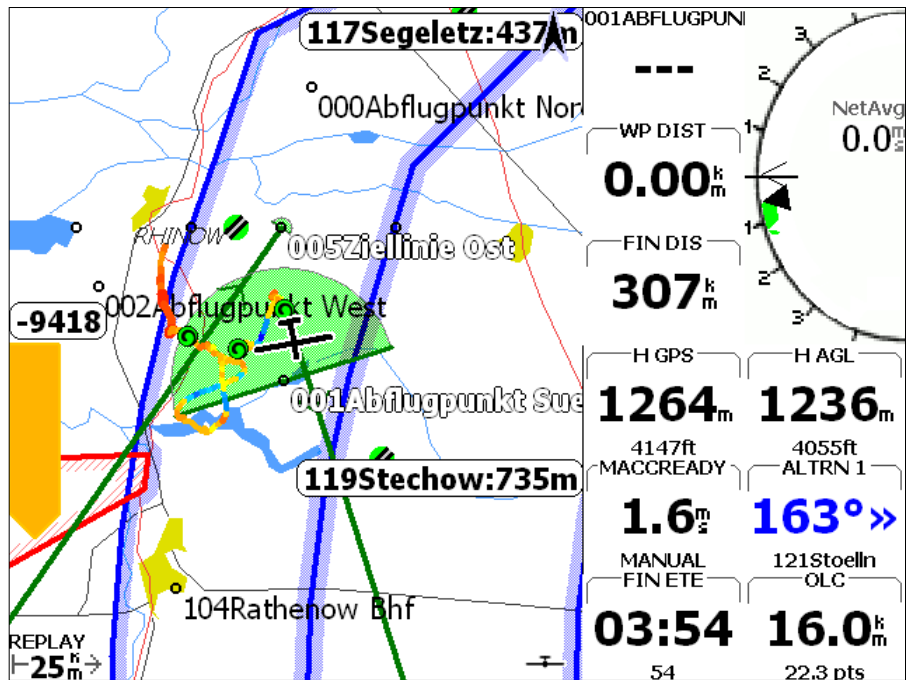

15.4 Digi-FLYBOX TELEMETRY TO XCTRACK

- The free **XCTrack** software running on an external device (e.g. E-Reader, Smartphone, Tablet, etc.) receives, decodes and displays the **Digi-FLYBox Telemetry Data** sent in real time at high speed by the AIR via **Bluetooth BLE with auto reconnection** (recommended connection), via **Bluetooth SPP** or via **USB OTG cable**.

- **How to use telemetry communication via Bluetooth BLE with auto reconnection:**
 - On your AIR, do a one-time setting of the following parameters:
ADVANCED SETUP \ n. 23 TGPS = 1
ADVANCED SETUP \ n. 24 TAIR = DGF
ADVANCED SETUP \ n. 25 TFRQ = 3
ADVANCED SETUP \ n. 26 TCHA = BLE
ADVANCED SETUP \ n. 27 TAUT = ON
ADVANCED SETUP \ n. 28 T-ID = 1

 - To correctly decode the Digifly's telemetry, it is necessary (only once) to enter in the **XCTrack** : menu, Settings, select the "Sensors" sub-menu, select "use external Bluetooth sensor", select **Digifly Airnnn** (where "nnn" are the last three digits of your instrument's serial number), select "use external GPS", select "use external barometric sensor".

 - When you have done that once, the connection should be established automatically in the future, every time both **XCTrack** and the Digifly Air vario device are running.

- **How to use telemetry communication via Bluetooth SPP:**
 - On your AIR, do a one-time setting of the following parameters:
ADVANCED SETUP \ n. 23 TGPS = 1
ADVANCED SETUP \ n. 24 TAIR = DGF
ADVANCED SETUP \ n. 25 TFRQ = 3
ADVANCED SETUP \ n. 26 TCHA = SPP
ADVANCED SETUP \ n. 27 TAUT = ON
ADVANCED SETUP \ n. 28 T-ID = 1

 - In order to use the **XCTrack** software you must have already previously done (only once) the pairing procedure with the external device (see 13.2.1)

 - To correctly decode the Digifly's telemetry, it is necessary (only once) to enter in the **XCTrack** : menu, Settings, select the "Sensors" sub-menu, select "use external Bluetooth sensor", select **Digifly Airnnn** (where "nnn" are the last three digits of your instrument's serial number), select "use external GPS", select "use external barometric sensor".

 - The steps to follow each time you want to send the telemetry are:
 - 1) On the **AIR**, go to MENU "**Telemetry BT**".
 - 2) Run the **XCTrack** software on the external device.

3) When the AIR receives from the confirmation that it is connected the external device, it automatically exits from the "Telemetry BT" menu, returns to the current page of instruments, turns the Bluetooth icon on and activates the continuous transmission of real-time Digifly telemetry data at high speed. In case of problems, press the  key on the AIR to exit and try again.

▪ **How to use telemetry communication via USB-OTG cable:**

- On your AIR, do a one-time setting of the following parameters:

ADVANCED SETUP \ n. 23 TGPS = 1

ADVANCED SETUP \ n. 24 TAIR = DGF

ADVANCED SETUP \ n. 25 TFRQ = 3

ADVANCED SETUP \ n. 26 TCHA = USB

ADVANCED SETUP \ n. 27 TAUT = OFF

ADVANCED SETUP \ n. 28 T-ID = 1

- To correctly decode the Digifly's telemetry, it is necessary (only once) to enter in the XCTrack : menu, Settings, select the "Sensors" sub-menu, select "use external USB sensor", select "use external GPS", select "use external barometric sensor".
- The data will be continuously transmitted, except when you are in the Menu pages
- **Note:** use a USB OTG adapter and verify that the external device (e.g. Smartphone) also provides power supply through the USB cable; otherwise, it will be necessary to use a USB-OTG Y cable to provide 5V external power using, for example, a battery pack.

No drivers are required to use a USB-OTG (On-The-Go) cable.

- For more info about the XCTrack software please visit their website www.xctrack.org

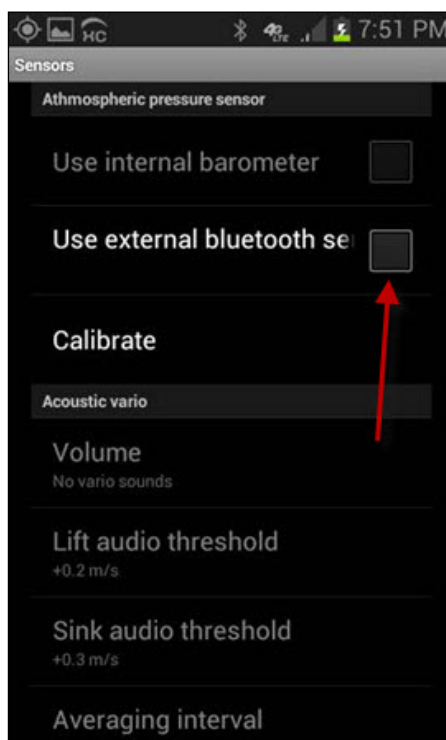
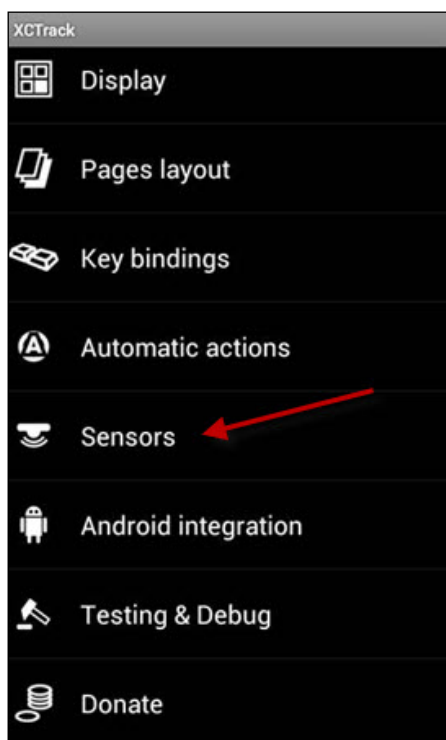

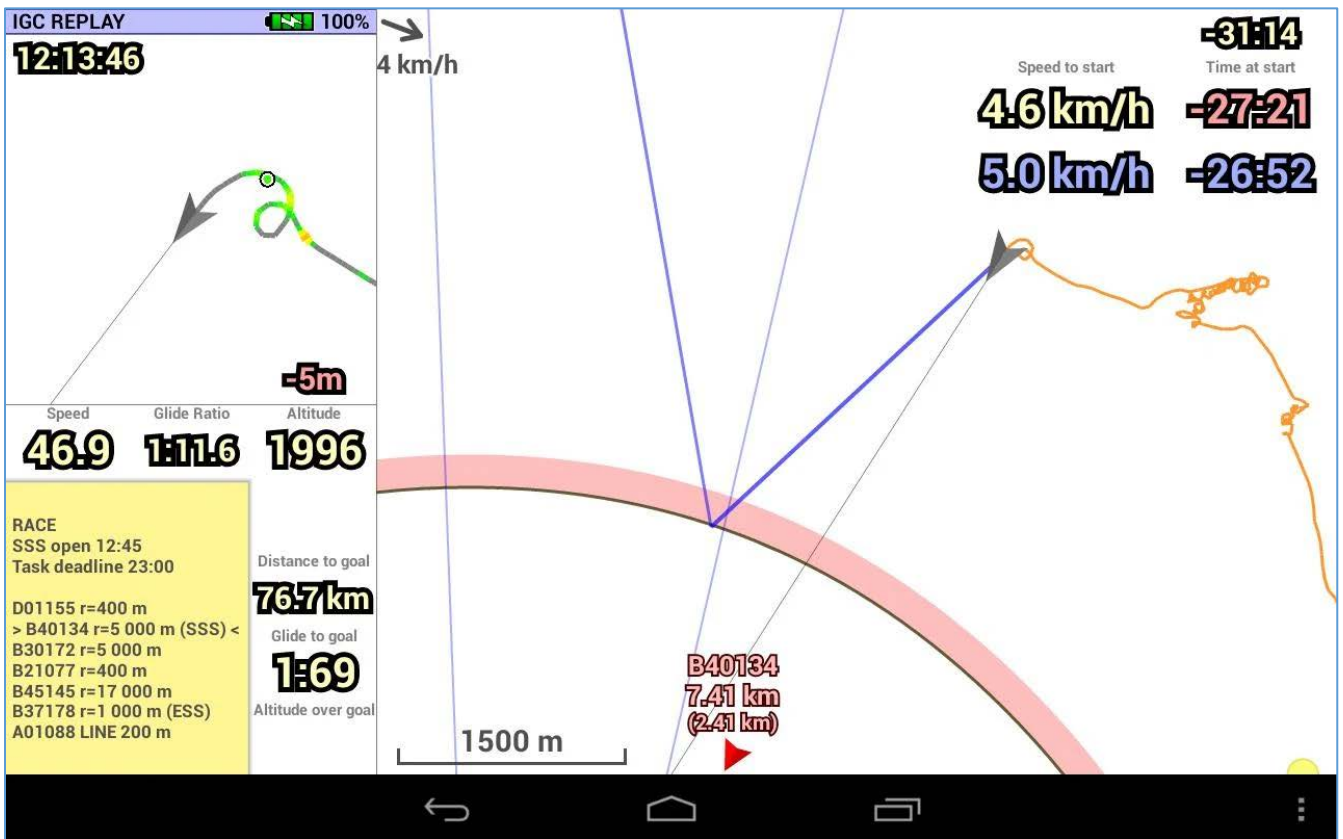

15.5 Digi-FLYBOX TELEMETRY TO TOPHAT

- The free **TopHat** software running on an external device (e.g. E-Reader, Smartphone, Tablet, etc.) receives, decodes and displays the **Digi-FLYBox Telemetry Data** sent in real time at high speed by the AIR via **Bluetooth**.

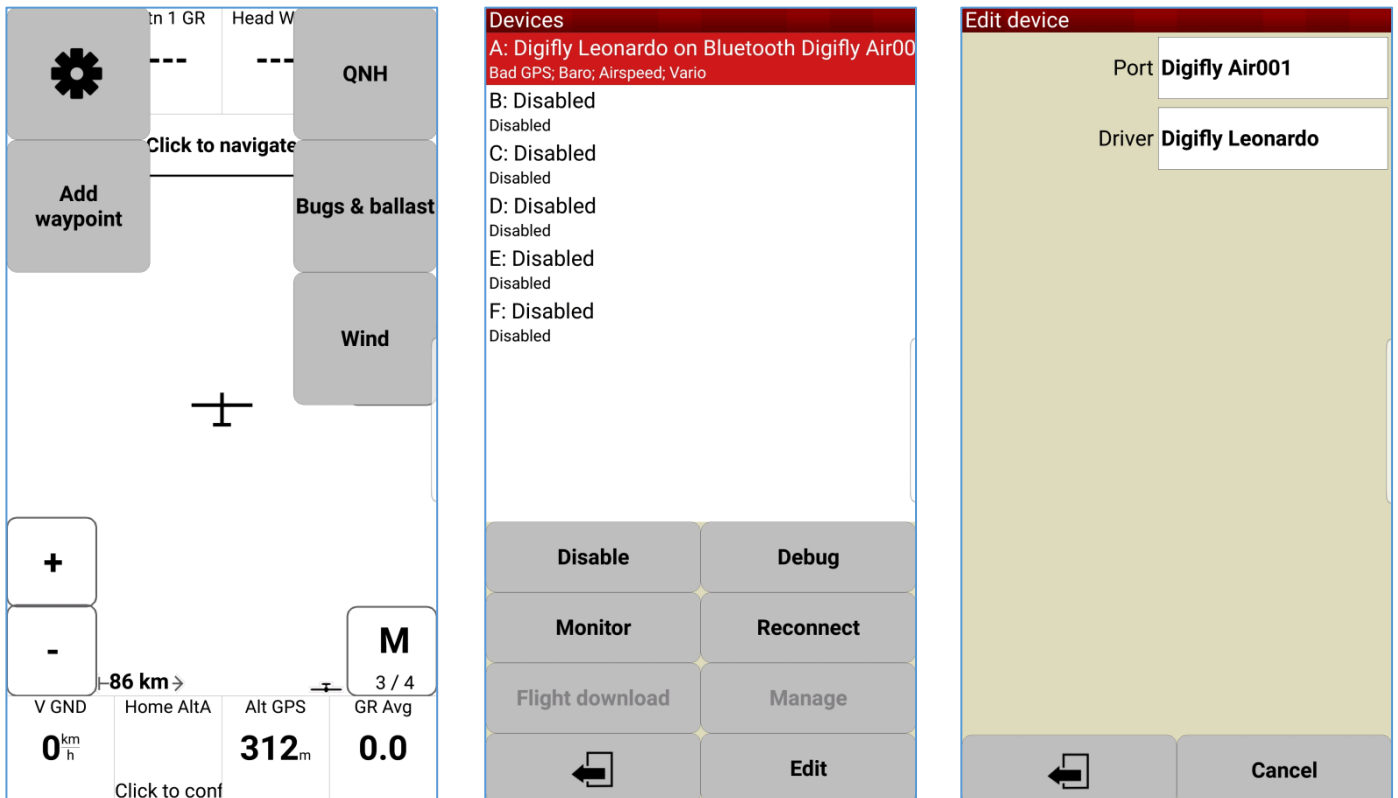

- How to use telemetry communication via Bluetooth SPP:**

- On your AIR, do a one-time setting of the following parameters:
 - ADVANCED SETUP \ n. 23 TGPS = 1
 - ADVANCED SETUP \ n. 24 TAIR = DGF
 - ADVANCED SETUP \ n. 25 TFRQ = 3
 - ADVANCED SETUP \ n. 26 TCHA = SPP
 - ADVANCED SETUP \ n. 27 TAUT = ON
 - ADVANCED SETUP \ n. 28 T-ID = 1
- In order to use the TopHat software you must have already previously done (only once) the pairing procedure with the external device (see 13.2.1)
- To correctly decode the Digifly's telemetry, it is necessary (only once) to enter in the TopHat : FLY mode, Menu 3/4, Set up TopHat, Devices, Edit Device A : Port: **Digifly Airnnn** (where "nnn" are the last three digits of your instrument's serial number), Driver: **Digifly Leonardo**, Close configuration.
- The steps to follow each time you want to send the telemetry are:
 - 1) On the **AIR**, go to MENU "**Telemetry BT**".
 - 2) Run the TopHat software on the external device.
 - 3) When the **AIR** receives from the confirmation that it is connected the external device, it automatically exits from the "Telemetry BT" menu, returns to the current page of instruments, turns the Bluetooth icon on and activates the continuous transmission of real-time Digifly telemetry data at high speed. In case of

problems, press the  key on the AIR to exit and try again.

- If everything is correct, the "Monitor" page in TopHat will display the telemetry data transmitted from the AIR
- For more info about the TopHat software please visit their website www.tophatsoaring.org/Download.html

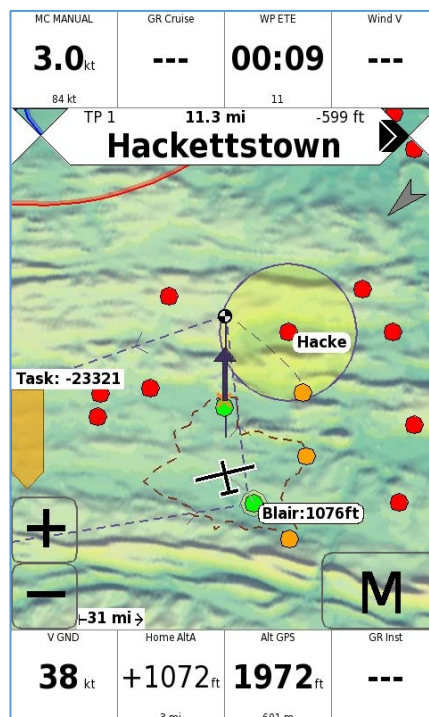
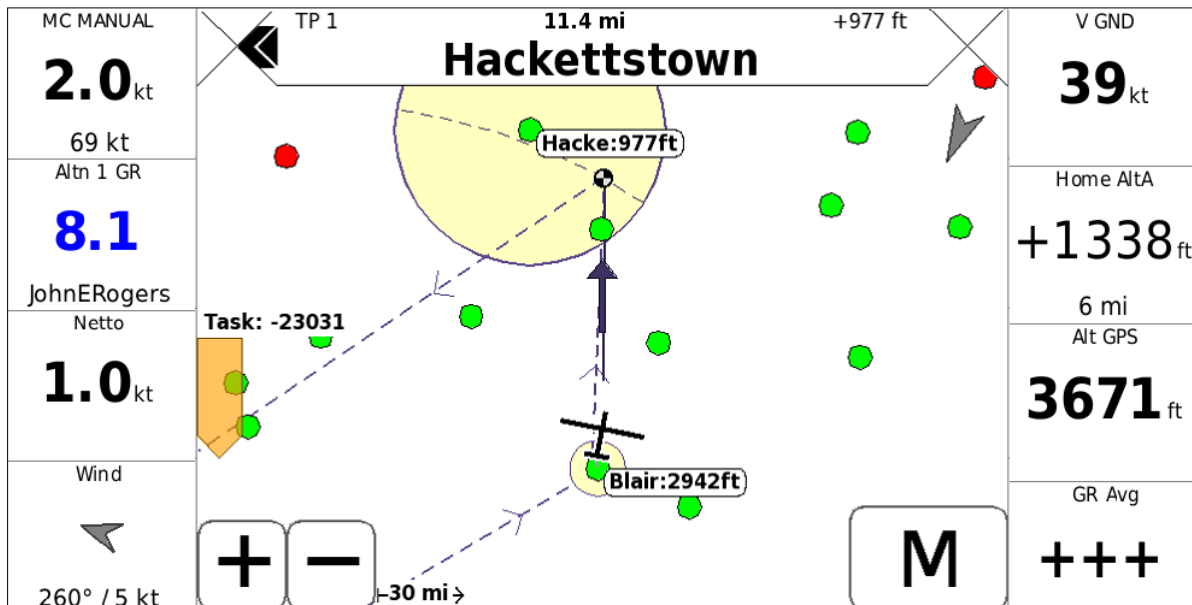

15.6 Digi-FLYBOX LIVE TRACK & TELEMETRY TO GPSDUMP

- The free **GpsDump** software (App Android) running on an external device (e.g. Smartphone, Tablet, etc.) receives the **Digi-FLYBox Telemetry Data** sent in real time at high speed by the AIR via **Bluetooth** , displays and sends them to the **Live Track** server (e.g. Livetrack24).

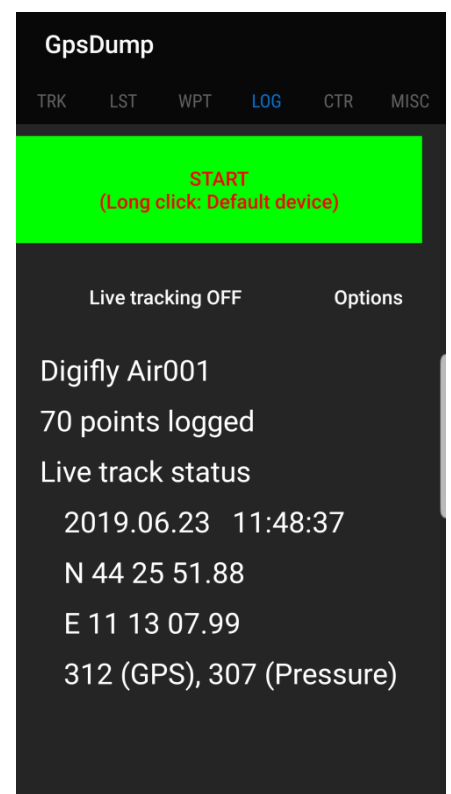
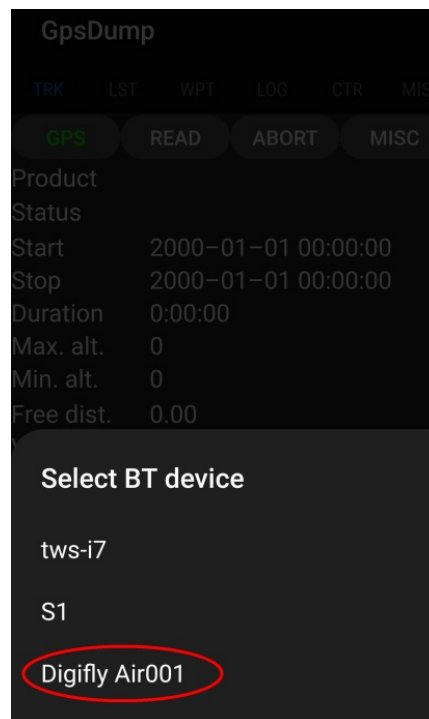
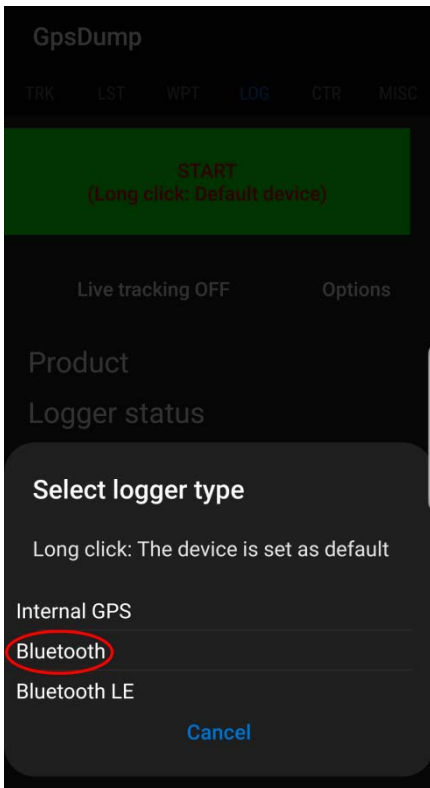
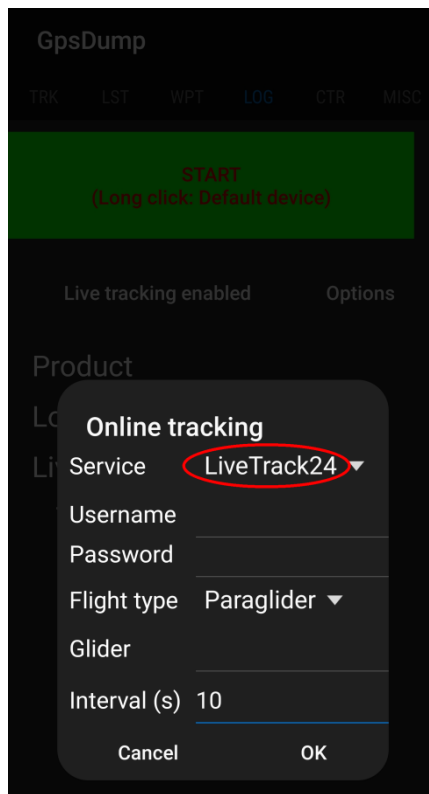
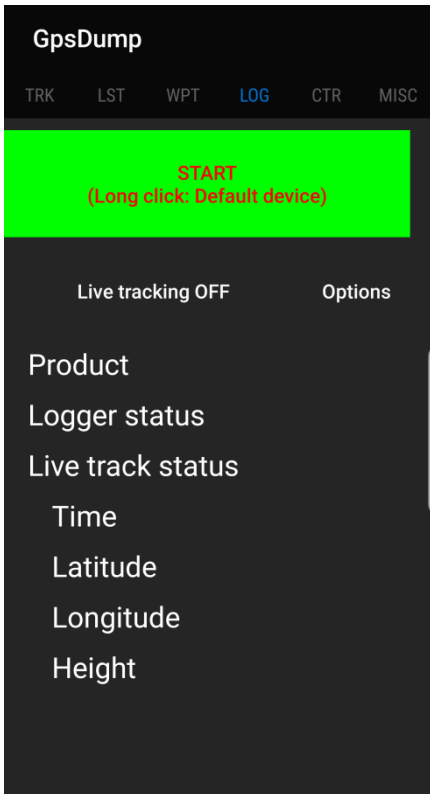

▪ **How to use Live Track & telemetry communication via Bluetooth SPP:**

- On your AIR, do a one-time setting of the following parameters:

ADVANCED SETUP \ n. 23 TGPS = 1

ADVANCED SETUP \ n. 24 TAIR = DGF

ADVANCED SETUP \ n. 25 TFRQ = 3

ADVANCED SETUP \ n. 26 TCHA = SPP

ADVANCED SETUP \ n. 27 TAUT = ON

ADVANCED SETUP \ n. 28 T-ID = 1

- In order to use the GpsDump software you must have already previously done (only once) the pairing procedure with the external device (see 13.2.1)
- To correctly decode the Digifly's telemetry, it is necessary (only once) to enter in the GpsDump : LOG Menu, click "**Live Tracking**", select "Service" : "LiveTrack24" and fill in the requested fields, press "START", "Select logger type" : long click "Bluetooth", "Select BT device" : click **Digifly Airnnn** (where "nnn" are the last three digits of your instrument's serial number).
- The steps to follow each time you want to send the telemetry are:
 - 1) On the **AIR**, go to MENU "**Telemetry BT**".
 - 2) Run the GpsDump software on the external device, LOG Menu, long click "START"
 - 3) When the **AIR** receives from the confirmation that it is connected the external device, it automatically exits from the "Telemetry BT" menu, returns to the current page of instruments, turns the Bluetooth icon on and activates the continuous transmission of real-time Digifly telemetry data at high speed. In case of problems, press the  key on the **AIR** to exit and try again.
- If everything is correct, the "LOG" page in GpsDump will display the telemetry data transmitted from the AIR
- For more info about this software please visit the GpsDump App page on the Google Play web site.

15.7 Digi-FLYBOX LIVE TRACK & TELEMETRY TO TTLIVETRACK24

- The free **TTLiveTrack24** software (App Android) running on an external device (e.g. Smartphone, Tablet, etc.) receives the **Digi-FLYBox Telemetry Data** sent in real time at high speed by the AIR via **Bluetooth** , displays and sends them to the **Live Track** server (e.g. Livetrack24).

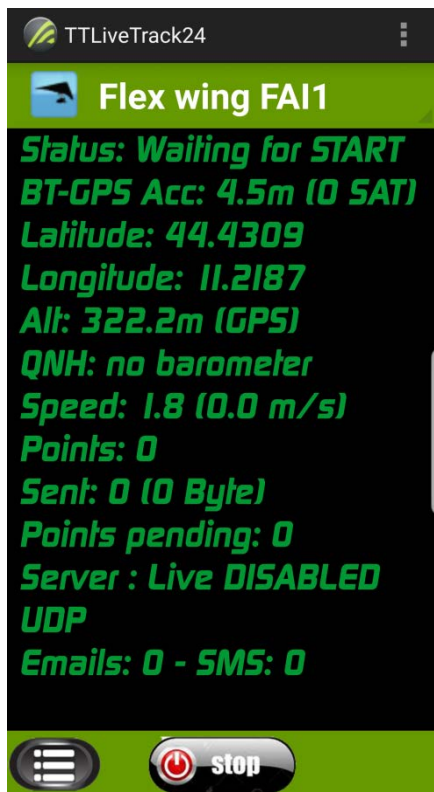
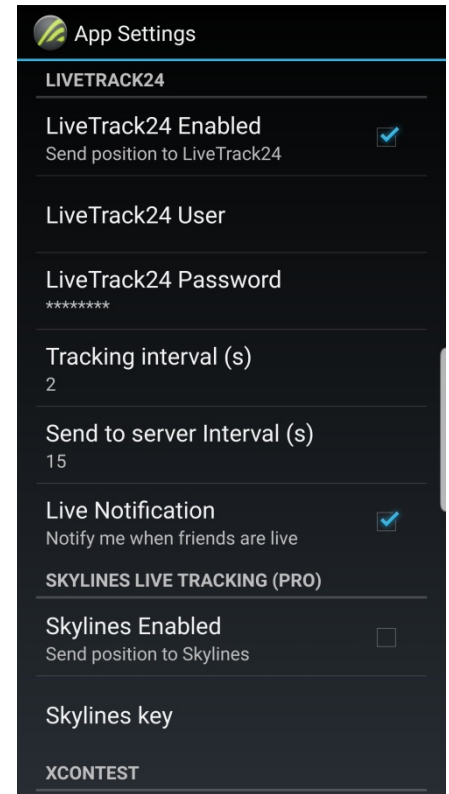
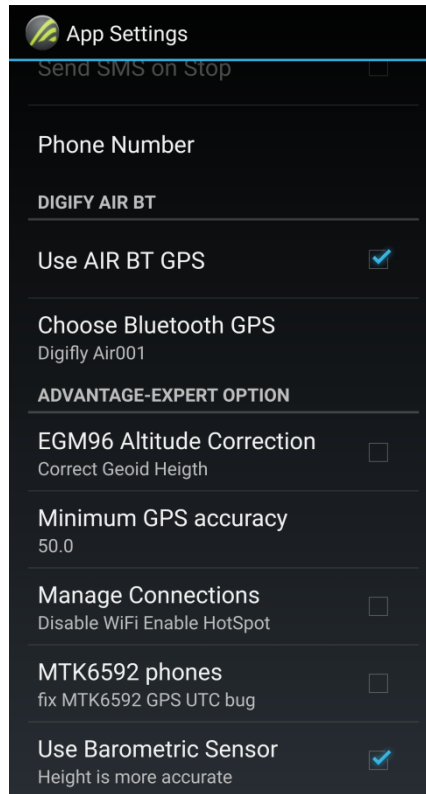
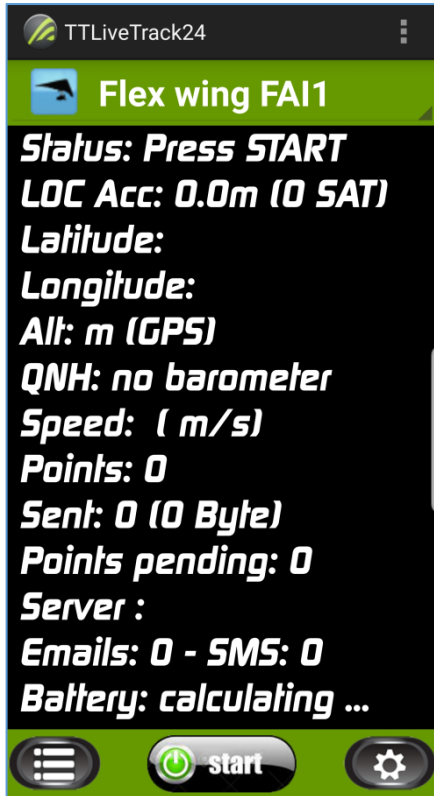

▪ **How to use Live Track & telemetry communication via Bluetooth SPP:**

- On your AIR, do a one-time setting of the following parameters:

ADVANCED SETUP \ n. 23 TGPS = 1

ADVANCED SETUP \ n. 24 TAIR = DGF

ADVANCED SETUP \ n. 25 TFRQ = 3

ADVANCED SETUP \ n. 26 TCHA = SPP

ADVANCED SETUP \ n. 27 TAUT = ON

ADVANCED SETUP \ n. 28 T-ID = 1

- In order to use the TTLiveTrack24 software you must have already previously done (only once) the pairing procedure with the external device (see 13.2.1)
- To correctly decode the Digifly's telemetry, it is necessary (only once) to enter in the TTLiveTrack24 : Settings Menu, tick the box next to "Use AIR BT GPS", "Choose Bluetooth GPS" : **Digifly Airnnn** (where "nnn" are the last three digits of your instrument's serial number), tick the box next to "LiveTrack24 Enabled" and fill in the requested fields.
- The steps to follow each time you want to send the telemetry are:
 - 1) On the **AIR**, go to MENU "**Telemetry BT**".
 - 2) Run the TTLiveTrack24 software on the external device, click "START"
 - 3) When the **AIR** receives from the confirmation that it is connected the external device, it automatically exits from the "Telemetry BT" menu, returns to the current page of instruments, turns the Bluetooth icon on and activates the continuous transmission of real-time Digifly telemetry data at high speed. In case of problems, press the  key on the **AIR** to exit and try again.

- If everything is correct, TTLiveTrack24 will display the telemetry data transmitted from the AIR
- For more info about this software please visit the **TTLiveTrack24** App page on the Google Play web site.

15.8 Digi-FLYBOX LIVE TRACK & TELEMETRY TO FLYSKYHY

- The Flyskyhy software (App Iphone) running on an external device (e.g. Smartphone, Tablet, etc.) receives the Digi-FLYBox Telemetry Data sent in real time at high speed by the AIR via Bluetooth BLE with auto reconnection, displays and sends them to the Live Track server (e.g. Livetrack24).

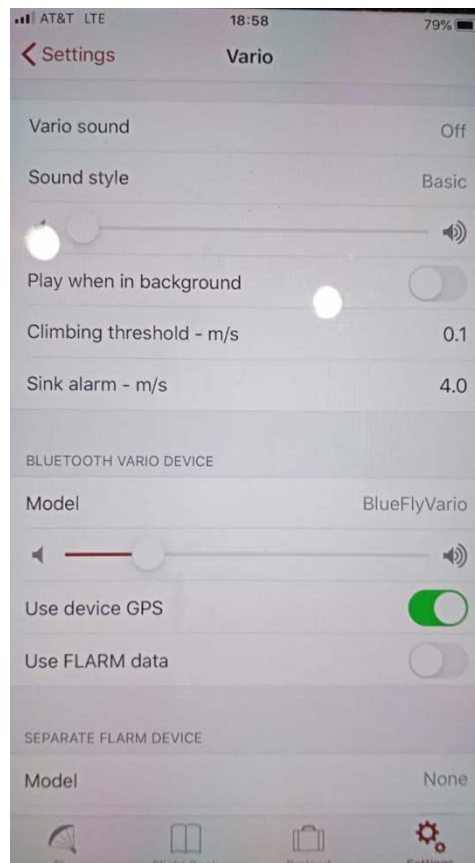
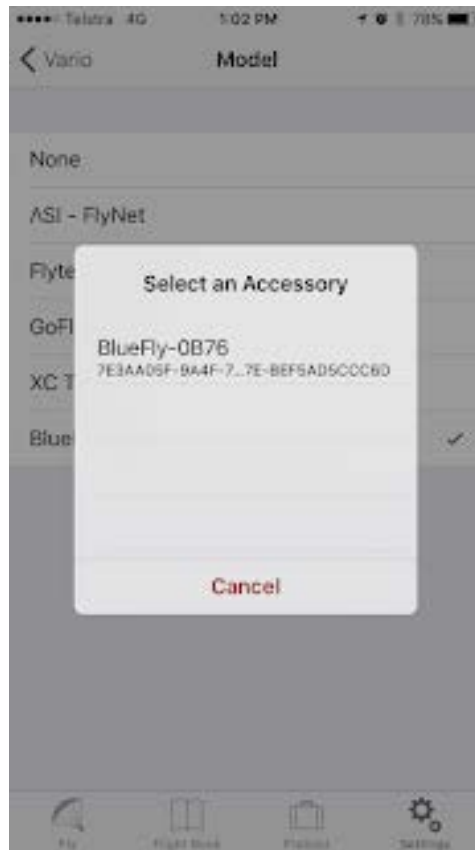

- **How to use Live Track & telemetry communication via Bluetooth BLE with auto reconnection:**
 - On your AIR, do a one-time setting of the following parameters:
ADVANCED SETUP \ n. 23 TGPS = 1
ADVANCED SETUP \ n. 24 TAIR = DGF
ADVANCED SETUP \ n. 25 TFRQ = 3
ADVANCED SETUP \ n. 26 TCHA = BLE
ADVANCED SETUP \ n. 27 TAUT = ON
ADVANCED SETUP \ n. 28 T-ID = 1
 - To correctly decode the Digifly's telemetry, it is necessary (only once) to enter in the Flyskyhy :
go into the Flyskyhy "Settings" menu, "Vario", "Model" , Select "Digifly Air" and the "Select an Accessory"
popup will come up. Switch on your Digifly Air vario device, and it should show up in the popup after a while.
Select it, and a connection will be established.
When you have done that once, the connection should be established automatically in the future, every time
both Flyskyhy and the Digifly Air vario device are running.
- If everything is correct, Flyskyhy will display the telemetry data transmitted from the AIR
- For more info about this software please visit the <https://flyskyhy.com/index.html> web site.

15.9 TELEMETRY BIDIRECTIONAL COMMANDS

- The Telemetry command interpreter, executes the inbound commands received on the Telemetry channel (via USB cable or via Bluetooth) previously set on the **ADVANCED SETUP \ n. 26 TCHA** parameter “Telemetry Communication Channel”: OFF(default), USB, SPP or BLE
- All the incoming commands must follow the NMEA string format:
\$PDGFabc,p1,p2,p3*cc[CR][LF] and have a valid NMEA checksum.
The string allows for a maximum of 100 characters.

The Digify Air always replies, once the operation is complete, with a copy of the inbound command or with an error message:

```
$PDGFERR*50[CR][LF]
```

The external device must always wait for the reply from the Digify Air before sending a new command

Sound volume setting commands:

```
$PDGFVLO*3F[CR][LF] sets the volume Off
```

```
$PDGFVL1*3E[CR][LF] sets the volume Low
```

```
$PDGFVL2*3D[CR][LF] sets the volume High
```

The sound alert command is adjustable and can be combined in up to 4 “tone-duration” pairs

tone range: 0= mute, 250-3000hz

duration range: 50-500ms

```
$PDGFALM,tone1,duration1,tone2,duration2,tone3,duration3,tone4,duration4*cc[CR][LF]
```

Accepted formats:

```
$PDGFALM,tone1,duration1*cc[CR][LF]
```

```
$PDGFALM,tone1,duration1,tone2,duration2*cc[CR][LF]
```

```
$PDGFALM,tone1,duration1,tone2,duration2,tone3,duration3*cc[CR][LF]
```

```
$PDGFALM,tone1,duration1,tone2,duration2,tone3,duration3,tone4,duration4*cc[CR][LF]
```

Examples:

```
$PDGFALM,500,200*52[CR][LF] // single short beep
```

```
$PDGFALM,1000,200*66[CR][LF] // single short beep
```

```
$PDGFALM,1500,200*63[CR][LF] // single short beep
```

```
$PDGFALM,1000,500*61[CR][LF] // single long beep
```

```
$PDGFALM,1000,200,0,100,1000,200*54[CR][LF] // beep(1000, 200); DelayMs(100); beep(1000, 200); //  
double beep
```

```
$PDGFALM,310,400,520,400,310,400,520,400*55[CR][LF] // beep(310, 400); beep(520, 400); beep(310,  
400); beep(520, 400);
```

```
$PDGFALM,1500,200,3000,200,1500,200,3000,200*55[CR][LF] // beep(1500, 200); beep(3000, 200);  
beep(1500, 200); beep(3000, 200);
```

16 APPENDIX

16.1 DIGIFLY AIR STANDARD ACCESSORIES

The Digifly AIR-PRO and AIR-HG are shipped with the following standard accessories:

- Protective padded bag (AIR-PRO).
- Internal rechargeable lithium battery.
- USB PC cable for flights download, managing other functions and firmware updates directly from the Internet.

16.2 OPTIONAL ACCESSORIES

The following optional accessories are available from Digifly:

- Integrated Anemometer (Airspeed Sensor - Pitot tube)
- Hang gliding vario mount
- Paragliding protective soft case and/or chest mount
- AIR-HG Cover

16.3 TECHNICAL FEATURES

16.3.1 STANDARD FUNCTIONS

- Graphic altimeter
- Altimeters 9,000 m (29527ft)
- A1 altimeter with optional automatic synchro with GPS altitude at take-off.
- Adjustable Max. A1 altitude alarm
- A2 automatic Altimeter that synchronizes with the altitude as you take off
- A3 automatic "thermal gain" altimeter
- QNE Altimeter
- FL (Flight Levels) Altimeter
- Above ground altimeter AGL, when using the Topographic Maps functions
- Thermal Tutor with auto-zoom and real time thermal plotter with different thickness depending on the lift
- Thermal Assist with customizable size and scale
- 11-Sensors Vario (barometer + 9 sensors synthetic inertial platform + Pitot sensor) with **self-adaptive sensitivity** function
- Digital vario +/- 25 m/s (5000 ft./min)
- Analogue vario +/- 25 m/s (5000 ft./min)
- Vario integrator adjustable from 5 to 60 sec
- Acoustic vario with adjustable volume and tone levels plus vario simulator function
- Acoustic vario with "pre-thermal" function
- Acoustic vario with "auto-silence" function
- Net Vario (with optional Pitot tube)
- Total energy compensation (with optional Pitot tube)
- McCready and Equivalent McCready function (with optional Pitot tube)
- Acoustic McCready function (with optional Pitot tube)
- Airspeed IAS / TAS (with optional Pitot tube)
- Adjustable stall alarm (with optional Pitot tube)
- Speed Difference (with optional Pitot tube)
- Speed to Fly (with optional Pitot tube)
- 3 adjustable polar curves (with optional Pitot tube)
- Barometer (range 300 to 1200mB) with user's calibration
- Constant battery monitoring.
- Date and time, with auto GPS synchro, chronometer, flight timer.

16.3.2 ADVANCED FUNCTIONS

- 3-axis synthetic inertial platform.
- 3-axis synthetic compass
- 3-axis synthetic accelerometer
- Integrated Digi-FLYBOX (sensor box) with high speed telemetry via USB cable and via Bluetooth to LK8000, XCSOAR, XCTrack, GpsDump, TTLiveTrack24, Flyskyhy and many other free apps.
- Condor simulator compatible
- Intellify function with automatic page switching feature.

16.3.3 GPS FUNCTIONS

- Integrated high sensitivity GPS multi-constellation receiver with 99 channels and 10Hz
- Latitude, Longitude, Altitude GPS, Direction GPS (TRK), Ground Speed GPS
- Efficiency (Glide Ratio) related to the ground (with GPS ground speed)
- Distance from Take-Off (TKF)
- Wind speed and direction indicator (with GPS)
- Position and distance of the last thermal
- HSI graphic navigation function
- "Follow Me" Navigation function
- "GOTO HOME" Navigation function
- "GOTO LANDINGS" and "GOTO NEAREST" Navigation functions
- Direction, distance, height, efficiency and time to the current Waypoint
- Direction, distance, height, efficiency and time to the GOAL
- Route navigation is continuously optimized and recalculated every second in real time, indicating the shortest path along the route
- Glide Computer
- Adjustable distance calculator parameter: Ellipsoid WGS84 , FAI Sphere, Tolerance percentage
- Real Time Navigation Manager with "Skip Waypoint" function
- Automatic FAI cylinder turn point and Start Waypoint validation (visual and acoustic)
- Start Waypoint full management with indications of: start gate opening time, time to opening, estimated relative time to the Start cylinder, requested speed to arrive to the Start cylinder
- Automatic Start Waypoint display switching function
- 186 Competition Waypoints + 186 User Waypoints
- 12 Routes with 20 Waypoints on each Route
- Multi-flight logger, 3D recorder (flight data and GPS) with Auto-start and Auto-stop
- Saves a copy of the tracklog in FAI-CIVL Cat.1 Certified IGC format on the microSD card
- 100,000 data points flight recorder: from 1,800 hours (1 point per minute) to 30 hours (1 point per second)
- Up to 250 recordable flights.
- FREE worldwide digital topographic Maps
- Real-time AGL altimeter (using the free topographic maps' elevation information).
- 3D Controlled airspaces (CTR) management, up to 1000.
- FAI Triangle Assistant

16.3.4 GENERAL SPECIFICATIONS

- Very high resolution, gray scale, graphic LCD display 320x240 pixels
- 13 Graphic screens from which 12 are completely configurable by the user with simple "drag & drop" technique using the graphical free software Digifly AirPages for PC and Mac
- Free Digifly AirTools vario management software for PC and Mac
- Compatible with most competition software programs, with Online XC Contest and with GpsDump free software

for PC, Mac and Android Smartphone

- USB data communication
- Bluetooth Dual Mode SPP / BLE data communication
- High Speed real time Digifly Telemetry data output 10 times per second via USB cable and via Bluetooth
- Integrated Digi-FLYBOX (sensor box) with high speed telemetry via USB cable and via Bluetooth to LK8000, XCSoar, XCTrack, GpsDump, TTLiveTrack24, Flyskyhy and many other free apps.
- Condor simulator compatible
- Free Firmware updates via Internet
- Additional memory capacity using a microSD memory card (8GB/16GB/32GB Class 10 formatted to FAT32)
- Data transfer (waypoints, routes, pages, sound profiles) between instruments using the microSD card
- FREE worldwide digital topographic maps
- 14 Languages for “Help” texts setup
- Adjustable units of measure
- Ready for installation of the optional Pitot tube and sensor kit
- Input for external power supply
- Integrated battery charger via USB socket
- Battery life 20 hours with the integrated rechargeable lithium battery
- Dimensions (H x L x D) 152mm x 86mm x 20mm / Weight -with battery- 180g (0.4lb or 6.4oz)
- The Digifly AIR instruments are supplied with a rechargeable internal lithium battery and USB cable
- **3-year warranty.**

16.4 MAIN SET UP PARAMETERS

n	Name	Description	Range	Default	Units
1	CTRS	display contrast setting	1 - 99	36	%
2	LANG	language selection	USR/ UK /ITA/ESP/DEU/FRA/CZE/HUN/PLN/GRK/TRK/LN1/POR/CAT		
3	RECM	recorder mode selection	OFF/ALW/AUT	AUT	---
4	R.DS	meters variation start autorecorder	0.1 - 5	0.5	mt
5	R.TI	seconds variation start autorecorder	1 - 30	3	sec
6	RECR	recorder rate	1 - 60	3	sec
7	UTCO	time zone difference	-15/+15	+02	ore
8	CORD	GPS lat lon coordinates format	DMM/DMS/UTM/DDD	DMS	---
9	U-AL	altimeter units	MT/FT	MT	---
10	U-SP	speed units	KMH/MPH	KMH	---
11	U-DS	distance units	KM/MIL	KM	---
12	PILO	pilot's name	6 characters	ABCDEF	---
13	GTYP	glider type	6 characters	ABCDEF	---
14	GID	glider ID	6 characters	ABCDEF	---
15	PG01	Page 1 mode	OFF/STD/USR	OFF	---
16	PG02	Page 2 mode	OFF/STD/USR	OFF	---
17	PG03	Page 3 mode	OFF/STD/USR	OFF	---
18	PG04	Page 4 mode	OFF/STD/USR	OFF	---
19	PG05	Page 5 mode	OFF/USR	OFF	---
20	PG06	Page 6 mode	OFF/USR	OFF	---
21	PG07	Page 7 mode	OFF/STD/USR	STD	---
22	PG08	Page 8 mode	OFF/STD/USR	STD	---
23	PG09	Page 9 mode	OFF/STD/USR	STD	---
24	PG10	Page 10 mode	OFF/STD/USR	STD	---
25	PG11	Page 11 mode	OFF/STD/USR	STD	---
26	PG12	Page 12 mode	OFF/STD/USR	STD	---
27	IFLY	Intellifly mode	OFF/XCM/XCA/CPM/CPA	XCA	---

16.5 VARIOMETER SETUP PARAMETERS

n	Name	Description	Range	Default	Units
1	V.UP	acoustic vario lift setting	0 - 2.00	00.10	m/s
2	V.PT	acoustic vario pre-thermal setting	0 - 1.50	00.50	m/s
3	V.DN	acoustic vario sink setting	0 - 25.00	02.50	m/s
4	DYNH	dynamic frequency change enable	OFF/ON	ON	---
5	DUMP	average frequency change	1 - 15	15	---
6	PTMD	pre-thermal mode	0 - 1	0	---
7	PROF	acoustic vario profiles SFT/STD/FAS/US1/US2/MAN/DG1/DG2/DG3/DG4DG2			---
8	UPHZ	base frequency in lift	400 - 1400	500	Hz
9	MODH	frequency modulation in lift	1 - 25	14	---
10	CURH	frequency modulation curve type	1 - 4	2	---
11	TONB	base Ton time in lift	100 - 1000	400	mS
12	TOFB	base Toff time in lift	0 - 1000	300	mS
13	PITC	tone rhythm in lift	0 - 10	2	---
14	DWHZ	base frequency in sink	350 - 1000	400	Hz
15	RVAR	Acoustic vario sensitivity	1 - 20	10	---
16	INTE	integrator vario delay	5 - 60	10	sec
17	DSEL	vario bar graph mode	0/1/2/3/4	0	---
18	SIMV	vario simulator	0 - 4	0	---
19	AUTV	automatic acoustic vario	OFF/ON	ON	---

16.6 ADVANCED SETUP PARAMETERS

n	Name	Description	Range	Default	Unit
1	PITO	Pitot tube enable	OFF/IAS/TAS	IAS	---
2	STAL	Stall alarm	0 - 150	0	km/h
3	SDIF	Speed difference enable	OFF/ON	OFF	---
4	OFSP	Pitot tube offset calibration	0 - 4000	0	---
5	KIAS	airspeed calibration	50 - 200 %	100	%
6	TECM	Total energy compensation mode	OFF/ON/FULL	OFF	---
7	TEC	Total energy compensation value	0 - 100	50	%
8	TECA	Total energy compensation average	0 - 99	80	---
9	KBAR	barometer calibration	+/- 10.0	0.0	mB
10	A1AL	Altitude alarm A1	0 - 9000	0	mt
11	A1SY	enable A1 - AGPS synchronizing	OFF/ON	ON	---
12	A2AU	A2 altimeter automatic reset (to 0)	OFF/ON	ON	---
13	CTRM	CTR mode setting	OFF/ON	OFF	---
14	CTRD	CTR distance warning (horizontally)	0 - 9999	400	mt
15	CTRH	CTR vertical separation warning	0 - 999	400	mt
16	ELVM	elevation mode setting	0 - 3	0	---
17	ELVB	elevation base height setting	0 - 4000	0	mt
18	ELVS	elevation step setting	10 - 1000	100	mt
19	FAIT	FAI Triangle Assistant	OFF/ON	OFF	---
20	THEZ	thermal tutor zoom level	1 - 100	1	---
21	THEA	thermal assist zoom level	1 - 20	5	---
22	SKPW	Skip Waypoint shortcut enable	OFF/ON	OFF	---
23	TGPS	telemetry Gps output enable	0 - 1	0	---
24	TAIR	telemetry AirData protocol type	DGF/LK8/LXW/_PR/PRS/BF5/BF6	DGF	---
25	TFRQ	telemetry AirData output rate	0 - 10	0	---
26	TCHA	telemetry communication channel	OFF/USB/SPP/BLE	OFF	---
27	TAUT	telemetry BT auto connection	OFF/ON	OFF	---
28	T-ID	telemetry BT id	1 - 2	1	---
29	ACHA	Airtools communication channel	USB/SPP/BLE	USB	---
30	A-ID	Airtools BT id	1 - 2	1	---

16.7 GLIDE COMPUTER SETUP PARAMETERS

n	Name	Description	Range	Default	Units
1	DTOL	Distance tolerance	0.0 - 0.5 % 0.0	%	
2	DCAL	Distance calculation mode	FAI/WGS	WGS84	---
3	CRUT	Glide detect time threshold	2 - 20	15	sec
4	THET	Thermal detect time threshold	1 - 30	2	sec
5	WMOD	Wind mode	(1=automatic , 2=manual)	1	---
6	MWSP	Manual wind speed	0 - 99	0	km/h
7	MWDR	Manual wind direction	0 - 359	0	---
8	WSEN	Wind calculator sensibility	3 - 15	5	---
9	GLDM	Glide mode	LST/MAN/AUT	LST	---
10	MEFF	Manual glide ratio	1.0 - 50.0	5.0	---
11	EFF	Real time average glide ratio	1 - 30	3	sec
12	EFFA	Average glide ratio for HW calc	1 - 99	99	sec
13	MMCR	Manual McCreeady	0 - 5.0	0	m/s
14	MCRA	McCreeady average time	0.2 - 30	10.0	min
15	MCRE	McCreeady equiv. average time	0.1 - 3	0.4	sec
16	MCRS	McCreeady sound enable	0 - 2	0	---
17	HWPM	Hwpm parameter (future use)	0 - 1	0	---
18	AUX1	Aux1 parameter (future use)	0 - 2	0	---
19	BLST	Ballast kg	0 - 250	0	kg
20	POLA	Polar selection	OFF/P1/P2/P3	OFF	---
21	P1S1	Polar : speed 1	20 - 140	28	km/h
22	P1V1	Polar : vario 1	0.10 - 25.00	1.10	m/s
23	P1S2	Polar : speed 2	20 - 140	40	km/h
24	P1V2	Polar : vario 2	0.10 - 25.00	1.00	m/s
25	P1S3	Polar : speed 3	20 - 140	60	km/h
26	P1V3	Polar : vario 3	0.10 - 25.00	2.50	m/s
27	P1ST	Polar : speed type IAS / GS	0 - 1	0	---
28	P1TW	Polar : total weight kg	40 - 500	100	kg
29	P2S1	Polar : speed 1	20 - 140	34	km/h
30	P2V1	Polar : vario 1	0.10 - 25.00	0.94	m/s
31	P2S2	Polar : speed 2	20 - 140	42	km/h
32	P2V2	Polar : vario 2	0.10 - 25.00	1.00	m/s
33	P2S3	Polar : speed 3	20 - 140	62	km/h
34	P2V3	Polar : vario 3	0.10 - 25.00	2.00	m/s
35	P2ST	Polar : speed type IAS / GS	0 - 1	0	---
36	P2TW	Polar : total weight kg	40 - 500	137	kg
37	P3S1	Polar : speed 1	20 - 140	36	km/h
38	P3V1	Polar : vario 1	0.10 - 25.00	0.80	m/s
39	P3S2	Polar : speed 2	20 - 140	48	km/h
40	P3V2	Polar : vario 2	0.10 - 25.00	0.90	m/s
41	P3S3	Polar : speed 3	20 - 140	75	km/h
42	P3V3	Polar : vario 3	0.10 - 25.00	2.10	m/s
43	P3ST	Polar : speed type IAS / GS	0 - 1	0	---
44	P3TW	Polar : total weight kg	40 - 500	137	kg



Digifly Offices

Corporate Headquarters

Digifly Europe Srl
Bologna
Italy
Phone : +39 370 1167217
Web : www.digifly.com
E-mail : info@digifly.com

North, Central and South American Headquarters

Digifly USA
St. Augustine, FL
USA
Phone : +1 (240) 343-5987
Web : www.digiflyusa.com
E-mail : flydigifly@gmail.com